

Recommended Practice / February 2004

Issued by: Timber Queensland Limited

Scope

This data sheet provides general guidance on member sizes, connections and suitable materials for the construction of handrails and balustrades. The information provided in this data sheet does not preclude the use of manufacturer's proprietary information where this satisfies the requirements of the regulatory authority.

Introduction

For all Classes of building, handrails and balustrades are required to comply with the Building Code of Australia (BCA). The BCA requirements include design and construction provisions for the various components including compliance with the loading provisions of AS 1170.1 Structural design actions Part 1: Permanent, imposed and other actions.

For handrails and balustrades, the BCA is primarily concerned with the safety of building users and occupants. Design and construction must therefore take into consideration both the strength and durability of materials and components as well as the "geometric" constraints prescribed by the BCA to prevent people from accidentally falling through, under or over the balustrade.

The BCA should be consulted to determine where handrails and balustrades are required and for specific details regarding handrails for stairs, geometric limitations and other criteria.

Loads

AS 1170.1 requires balustrades and railings together with members and connections which provide structural support to be able to resist the following factored limit state loads - 0.9kN inward, outward and downward load at any point. It also requires balustrades and handrails to be able to resist a factored horizontal

or vertical loads of 0.53kN/m for all areas within or servicing exclusively one dwelling including stairs and landings but excluding external balconies and 1.13kN/m for external balconies in domestic and other residential buildings. Infill, including balusters, should be capable of resisting 0.75kN in any direction.

Note: In addition, AS 1170 recommends other design loads for specific conditions such as to restrain crowds or people under panic conditions. For this case, design to resist a uniform load of 4.5kN/m is required. For these conditions, handrail and balustrade systems should be specifically designed and are not covered in this data sheet.

Materials (Timber - general)

Durability

In **weather exposed** applications or, where subjected to other sources of moisture, handrails, posts, newels, balusters, and infill should be either naturally durable Class 1 or Class 2 species such as blackbutt, spotted gum, ironbark, jarrah, merbau or kwila with any sapwood present treated to H3 (or higher) or, H3 (or higher) treated softwood such as slash, hoop or radiata pine. Preservative treatment shall comply with AS 1604.

Note: Meranti, Victorian Ash and Tasmanian Oak are not suitable for weather exposed applications.

For **internal use**, timber of any durability class is suitable.

Timber Grade

The timber should be free from any major strength reducing features, be straight grained and be in accordance with the following:-

- Hardwood (Including Meranti) – AS 2796 – Timber - Hardwood – Sawn and milled products - Clear or select grade
- Softwood (Including imported softwood) – AS 1786 – Joinery timber milled from Australian grown conifers – Clear grade

Note: Finger jointed timber shall comply with AS 1491 – 'Finger jointed structural timber' and laminated timber shall comply with AS 1328 – 'Glued laminated structural timber'.

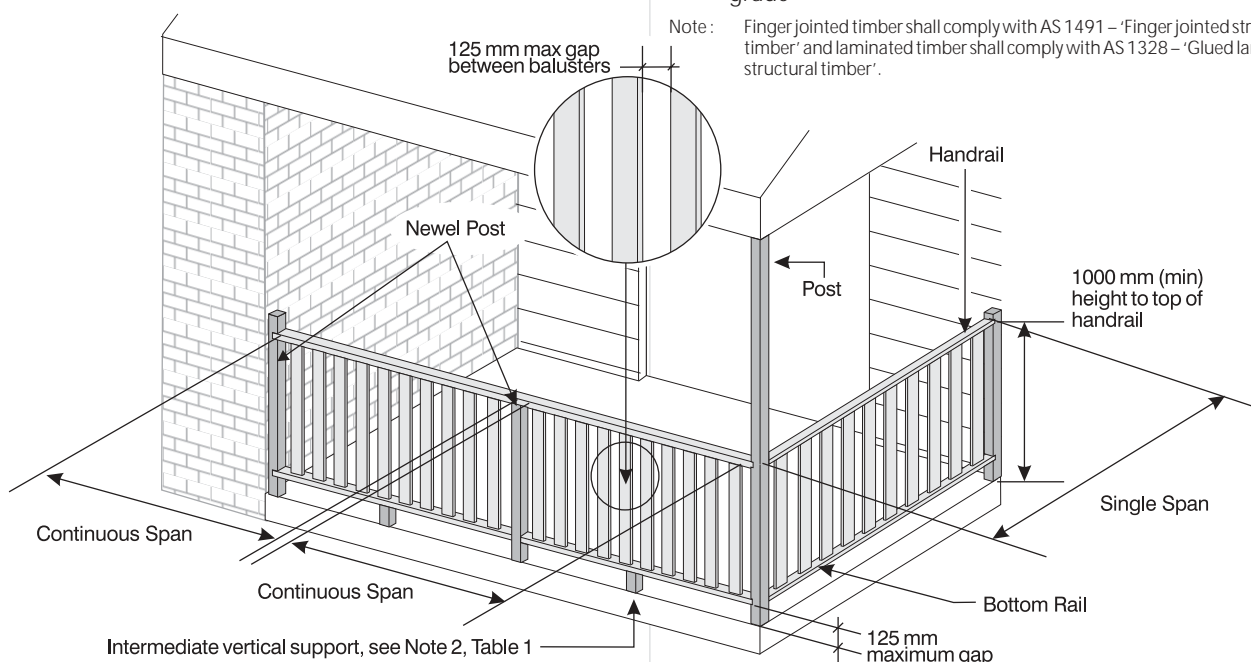

Figure 1. Balustrade terminology and dimensions

Materials (Structural Properties & sizes)

Handrails

Handrail sizes and spans shall be in accordance with Table 1.

Note: 1. Manufacturers that use this data sheet as the basis of their design should ensure that their products satisfy Australian Standards and have the relevant minimum mechanical properties including the following:-

Hardwood – Stress Grade F22, (characteristic bending strength $f'b = 65$ MPa, Modulus of elasticity $E = 16000$ MPa) and Joint Group JD2. Examples - spotted gum, ironbark, blackbutt, kwila and merbau.

Meranti and Australian Softwood – (characteristic bending strength $f'b = 25$ MPa, Modulus of elasticity $E = 9100$ MPa) and Joint Group JD4. Examples - radiata pine, hoop pine, slash pine and meranti.

Imported Softwood - (characteristic bending strength $f'b = 25$ MPa, Modulus of elasticity $E = 6900$ MPa) and Joint Group JD4. Examples - New Zealand radiata pine.

2. Unless branded to identify that it is 'Australian Grown', softwood balustrades spans shall be determined from the 'Imported Softwood' spans given in Table 1.

Posts / Newel Posts

Posts and Newel posts shall have a minimum Stress Grade of F5. Where supporting handrails/balustrades only, the minimum size of posts and newel posts shall be 80x80 mm (maximum post spacing 3600mm and height of 2700 mm).

Where supporting roof and or floor loads, refer to AS 1684 to determine minimum size but shall be not less than 80x80 mm.

Infill / Balusters

The minimum size of infill/balusters should be as follows:-

Hardwood - 19 x 19 mm or 21mm diameter

Softwood – 19 x 42 or 25 mm diameter

Corrosion Resistance

For weather exposed applications, all metal connections including nails, screws, bolts and brackets should be a minimum of hot dipped galvanised (or for screws, Class 3 corrosion resistance as per AS 3566). For coastal environments subjected to airborne salt deposition, stainless steel or equivalent corrosion resistant metal connections should be used.

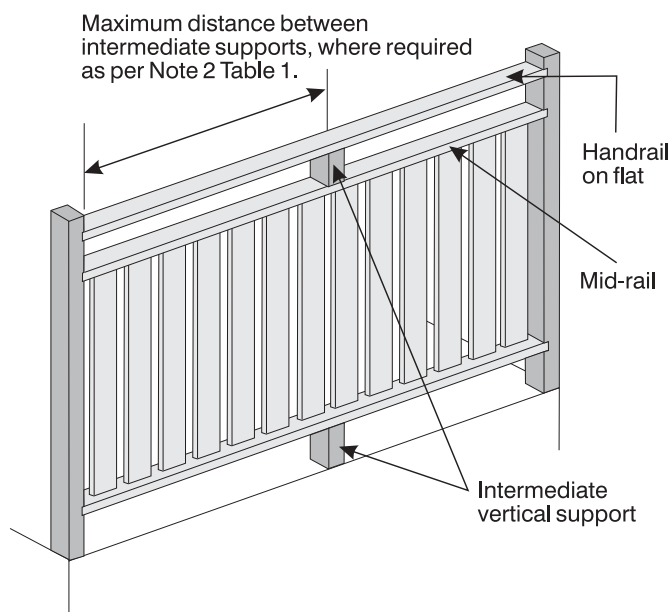

Figure 2. Intermediate Vertical Support

Table 1. - Handrails

| Timber | Size / Description | Maximum span of Handrail (mm) | | | |
|---------------------------------------|--------------------|---|--|---|--|
| | | Within or exclusively servicing one Dwelling (excluding external balconies) | | Other areas in Residential Buildings (including external balconies) | |
| | | No Intermediate Vertical Supports(1) | With Intermediate Vertical Supports(2) | No Intermediate Vertical Supports(1) | With Intermediate Vertical Supports(2) |
| Hardwood | 65 x 65 (profiled) | 3000 | 3000 | 3000 | 3000 |
| | 42 x 65 (profiled) | 2200 | 2700 | 2200 | 2700 |
| | 42 x 85 (profiled) | 2400 | 3400 | 2400 | 3400 |
| | 35 x 70 | 2100 | 3000 | 2100 | 3000 |
| | 35 x 90 | 2200 | 3600 | 2200 | 3600 |
| | 35 x 120 | 2400 | 3600 | 2400 | 3600 |
| | 45 x 70 | 2500 | 3200 | 2500 | 3200 |
| | 45 x 90 | 2700 | 3600 | 2700 | 3600 |
| | 45 x 120 | 2900 | 3600 | 2900 | 3600 |
| | 70 x 70 | 3500 | 3500 | 3500 | 3500 |
| 70 x 90 | 3600 | 3600 | 3600 | 3600 | |
| Meranti and Australian Grown Softwood | 65 x 65 (profiled) | 2700 | 2700 | 2200 | 2200 |
| | 42 x 65 (profiled) | 1400 | 2000 | 1400 | 1800 |
| | 42 x 85 (profiled) | 1800 | 3000 | 1700 | 2400 |
| | 35 x 70 | 1200 | 2400 | 1200 | 2000 |
| | 35 x 90 | 1600 | 3200 | 1600 | 2500 |
| | 35 x 120 | 2100 | 3600 | 1800 | 3400 |
| | 45 x 70 | 2000 | 2800 | 1800 | 2200 |
| | 45 x 90 | 2400 | 3400 | 2000 | 2900 |
| | 45 x 120 | 2600 | 3600 | 2400 | 3600 |
| | 70 x 70 | 3200 | 3200 | 2800 | 2800 |
| 70 x 90 | 3400 | 3600 | 3200 | 3600 | |
| Softwood Imported or Unknown Origin | 65 x 65 (profiled) | 2400 | 2400 | 2200 | 2200 |
| | 42 x 65 (profiled) | 1400 | 2000 | 1400 | 1800 |
| | 42 x 85 (profiled) | 1800 | 2700 | 1700 | 2400 |
| | 35 x 70 | 1200 | 2400 | 1200 | 2000 |
| | 35 x 90 | 1600 | 2900 | 1600 | 2500 |
| | 35 x 120 | 1900 | 3600 | 1800 | 3400 |
| | 45 x 70 | 2000 | 2600 | 1800 | 2200 |
| | 45 x 90 | 2200 | 3100 | 2000 | 2900 |
| | 45 x 120 | 2300 | 3600 | 2300 | 3600 |
| | 70 x 70 | 2900 | 2900 | 2800 | 2800 |
| 70 x 90 | 3000 | 3400 | 3000 | 3400 | |

Notes

1. Handrails with no intermediate vertical supports may be used on flat or on edge. See Figure 3.
2. Handrails with intermediate vertical supports shall be installed on flat with intermediate vertical supports spaced not greater than the allowable spans given for the same handrail with no intermediate vertical supports. See Figures 2 and 3.
3. Where a mid-rail (minimum size 42x65) is within 150mm of the main handrail and is rigidly fixed to it (using blocks, or balusters or dowels that pass through the mid rail and are fixed to the top rail) at least once at mid span, the allowable span of the handrail may be increased by 300mm.
4. Handrail spans have been limited to 3600 mm maximum.
5. Profiled sections typically include bread loaf, ladies waist and colonial profiles.
6. There is no negative tolerance permitted on the breadth or depth dimensions (overall outside dimensions of profiled shapes) given in the above table.

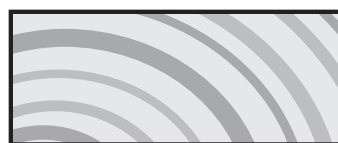

Handrail on Flat



Handrail on Edge

Figure 3. Handrails - on flat / on edge

Connections

Table 2 - Loads on Handrails

| Span Type | Handrail Span (mm) | Handrail Connection Loads (kN) | | EXAMPLE OF DETERMINING HANDRAIL CONNECTION |
|-----------------|--------------------|--|--|---|
| | | Within or exclusively servicing one Dwelling (exc. external balconies) | Other Areas in Residential Buildings (inc. external balconies) | |
| Single Span | 1800 | 0.90 | 1.0 | <p>The shaded areas in Tables 2 and 3 provide a guide to the selection of an appropriate connection for a Class 3 Building with a continuous span softwood handrail span of 2400mm.</p> <p>Step 1. From Table 2 determine the load on the handrail = 2.7 kN</p> <p>Step 2 From Table 3 and Figure 4, determine a connection with the capacity to resist 2.7 kN.</p> <p>Step 3 Acceptable solutions determined from Table 3 are:- Type A connection, 1/M10 bolt or Type B connection, 2/No 10 screws or Type D connection, 2 No 10 screws per leg of bracket</p> |
| | 2100 | 0.90 | 1.2 | |
| | 2400 | 0.90 | 1.4 | |
| | 2700 | 0.90 | 1.5 | |
| | 3000 | 0.90 | 1.7 | |
| | 3300 | 0.99 | 1.9 | |
| | 3600 | 1.1 | 2.0 | |
| Continuous Span | 1800 | 1.1 | 2.0 | |
| | 2100 | 1.3 | 2.4 | |
| | 2400 | 1.4 | 2.7 | |
| | 2700 | 1.6 | 3.0 | |
| | 3000 | 1.8 | 3.4 | |
| | 3300 | 2.0 | 3.7 | |
| | 3600 | 2.2 | 4.1 | |

Table 3. Capacity of Handrail Connections

| Timber | Capacity of Connections (kN) | | | | | | | | | | | |
|----------------------------|------------------------------|---------------------|------|------------|----------------------|---------|--------|------------|------------|--------|-------------------------------|--------|
| | Type A | | | Type B | | Type C | | | | Type D | | Type E |
| | No. Bolts | Bolt Size (Cuphead) | | No. Screws | Screw Size (Type 17) | | Screws | | Nails | | 2 / Screws per leg of bracket | |
| M10 | | M12 | No10 | | No14 | 2/No 10 | 2/No14 | 2/3.15 dia | 2/3.75 dia | No10 | No14 | |
| Hardwood (JD2) | 1 | 13 | 14 | 1 | 3.4 | 4.4 | 1.9 | 2.3 | 1.6 | 1.8 | 4.9 | 7.6 |
| | 2 | 26 | 28 | 2 | 6.8 | 8.8 | | | | | | |
| Softwood and meranti (JD4) | 1 | 8 | 9 | 1 | 2.0 | 2.6 | 1.1 | 1.3 | 0.9 | 1.0 | 2.8 | 4.3 |
| | 2 | 16 | 18 | 2 | 4.0 | 5.2 | | | | | | |

- Notes
- 1 For Type B connections, minimum screw penetration into post is 38mm.
 2. For Type C connections the minimum screw penetration into post is 40mm and the minimum nail penetration into post is 38mm.
 3. Midrails and bottom rails shall be fixed with a minimum of 2 / 3.15 dia. skew nails.

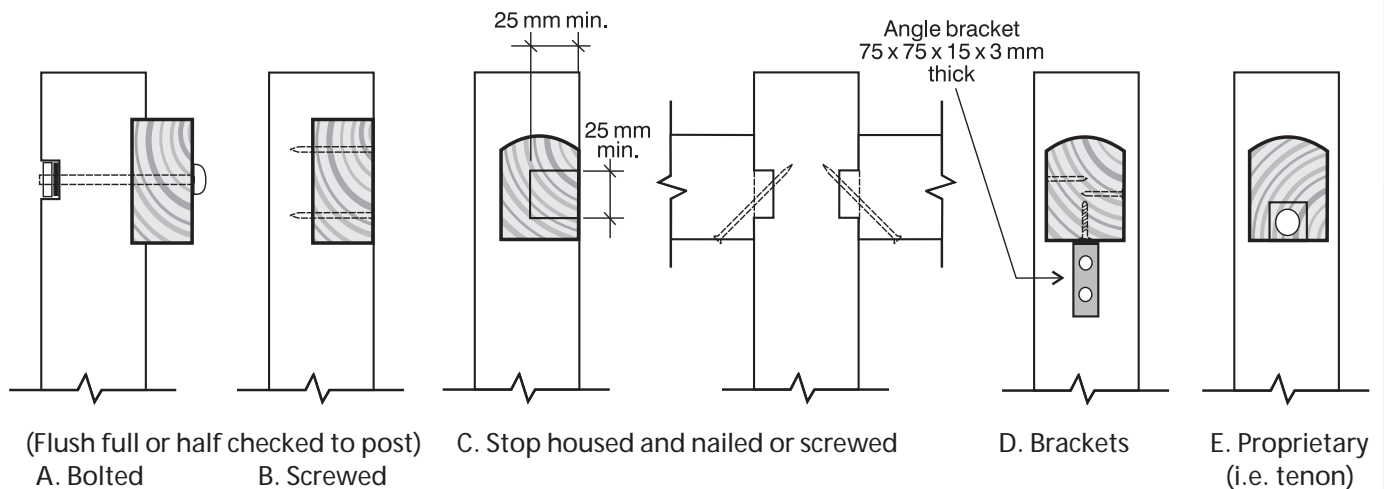

Figure 4. Handrail Connections

Table 4. - Connectors for Balusters / Infill

| Timber | Type A - Minimum Nail / Screw Penetration 'l' (mm) | | | | Type B - Nail in shear minimum penetration 'l' (mm) |
|----------------------------|--|--------------|-----------|------------|--|
| | Nails | | Screws | | |
| | 2 / 2.5 dia. | 2 / 2.8 dia. | 1 / No. 8 | 1 / No. 10 | |
| Hardwood (JD2) | 22 | 20 | 15 | 15 | 1 / 2.5 dia x 25 penetration |
| Softwood and meranti (JD4) | 53 | 47 | 15 | 15 | 2 / 2.5 dia x 25 penetration |

Notes: Where the balusters / infill are slotted into a groove or a dowel into a hole (i.e. top connection in Figure 5 Type A) that restrains both inward and outward forces, the above nail / screw fixing requirements are not applicable.

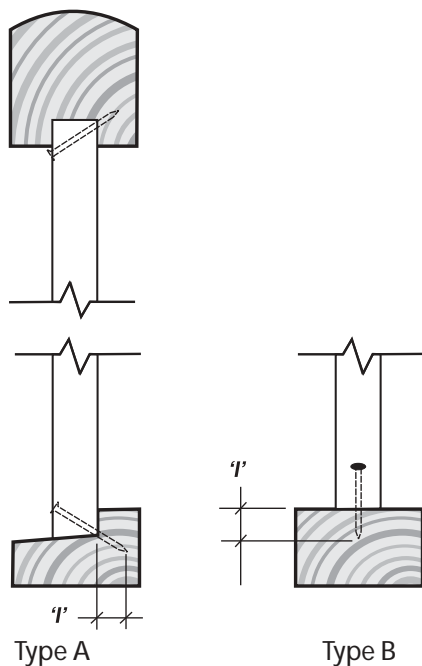

Figure 5. Balusters/Infill

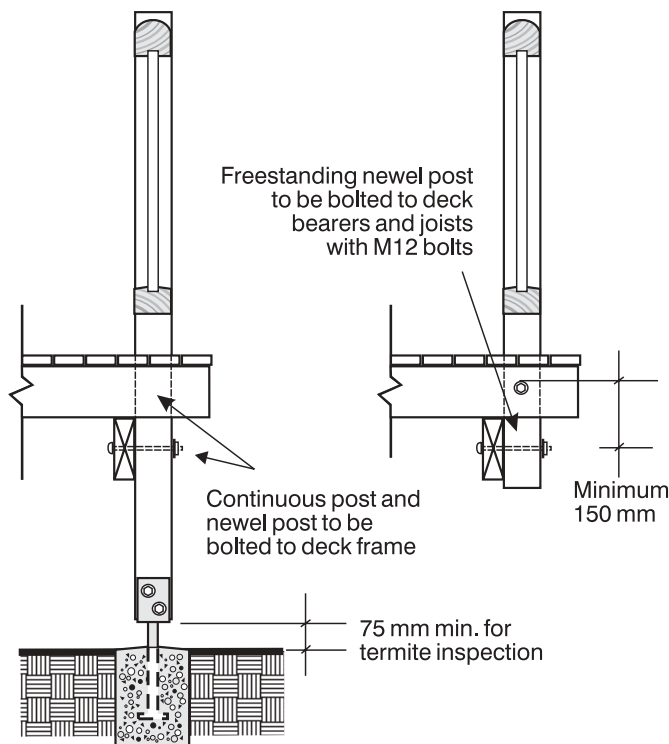

Figure 6. Post and Newel Post Connections

Painting and Finishing – External

Unprimed Timber

Nail holes should be stopped with an exterior grade wood filler.

Dirt or any loose material should be removed prior to coating.

All surfaces, ends and joints should be primed **prior to assembly** with a quality solvent based alkyd primer or stain, in accordance with manufacturers recommendations.

Final top coats of exterior paint or stain should then be applied in accordance with manufacturers recommendations.

Pre-primed LOSP Treated Timber

Pink pre-coated handrail and balustrade components should be sanded back and dusted off to remove any loose or powdery coatings prior to finishing.

Nail holes should be stopped with an exterior grade wood filler.

All surfaces, ends and joints should be primed **prior to assembly** with a quality, solvent based alkyd primer.

When the primer has dried in accordance with the manufacturers recommendations, apply two full coats of premium 100% acrylic exterior topcoat in accordance with manufacturers recommendations.



Timber Queensland Limited
 ACN 092 686 756 • ABN 50 092 686 756
 500 Brunswick Street, Fortitude Valley
 Brisbane Queensland 4006
 PO Box 2014, Fortitude Valley BC Qld 4006

Phone: (07) 3254 1989

Fax: (07) 3254 1964

Website: www.timberqueensland.com.au

Email: admin@timberqueensland.com.au

Whilst every effort is made to ensure the accuracy of advice given, Timber Queensland Limited cannot accept liability for loss or damage arising from the use of the information supplied.