

Recommended Practice / February 2004

Issued by: Timber Queensland Limited

Introduction

All buildings, building materials and building contents are subjected to a number of hazards throughout their useful life. These include corrosion of metal, spalling of concrete, fire and water damage. Another potential hazard is termite attack of some timbers and cellulose-based materials.

There are two main types of termites capable of attacking buildings: drywood termites, which do not have ground contact, and subterranean termites, which require contact with the ground or some other moisture source. Subterranean termites are distributed throughout Queensland and are responsible for most of the termite damage of economic significance.

This data sheet provides information on how to reduce the level of risk of subterranean termite attack.

Building Legislation

The Building Code of Australia (BCA) provides two options for the protection of buildings where a termite hazard is present.

- (i) Provision of barriers in accordance with AS 3660.1 to protect the whole building against termite infestation.
- (ii) Use of termite resistant materials for all structural elements; e.g. framing, bracing, flooring supported by joists, etc.

In addition, a Queensland variation to the BCA requires:-

- Underslab chemical barriers to be reticulated not hand sprayed; Perimeter chemical barriers to be protected by a 300 mm wide x 50 mm thick concrete cap; and
- Where termite resistant materials are used as a 'stand-alone' option, then in addition to structural elements, architraves, door jambs, window reveals & skirting must also be termite resistant.

Protect the Building and the Contents

Termite infestation can damage structural components, non-structural materials and contents, including joinery, plasterboard linings, furniture, books etc.

Buildings, therefore should be protected from termites for the structural framework as well as other building elements and contents.

Whole building protection systems have been designed to provide this overall protection but most require on-going maintenance and regular inspections to ensure integrity.

Where building owners seek greater security, additional protection for the structural framework can be provided by the use of termite resistant timber. The use of termite resistant timber may also be appropriate where future maintenance and inspections will be difficult or unlikely to be carried out.

It should be noted that the use of termite resistant framing alone will not protect contents and other non-structural elements from termite attack.

For traditional Queensland construction (i.e. using timber floors off the ground), protection is easily afforded by incorporating

physical barriers into the design, coupled with regular inspection of these barriers. Queensland's rich heritage of timber buildings is testimony to the effectiveness of these measures.

The risk of termite attack on buildings has increased with the change to construction methods dominated by concrete 'slab on ground' and masonry enclosed sub-floors. As a result chemical and physical barrier systems have been developed which, with proper maintenance and regular inspection, can prevent termite entry.

Minimising the Risk

(Prevention is better than the cure)

Correct building design, site preparation, construction practices and maintenance will contribute to the prevention of termite entry into buildings. The following notes are intended to supplement or emphasise points discussed in AS 3660.1.

Building Design

- Timber houses with elevated timber floors should be designed to ensure a physical barrier is installed between the lowest floor timber and the ground. This also applies to stairs, pergolas and decks that attach to the building (refer Figure 1). Termite resistant or preservative treated timber stumps and posts should be used to support floors (refer Termite Resistant Timbers). Other termite resistant materials may also be used.
- Sufficient under-floor crawl space (400 mm clearance to the underside of bearer) should be provided to enable easy inspection of physical barriers.
- Strip footings and slabs should be designed as integral components minimising construction breaks or construction joints as these provide avenues of termite entry.
- Services (pipes, plumbing, wiring etc.) should be installed where possible so that they do not penetrate through slabs or footings.
- Cavity brick or hollow masonry should be avoided below ground level. Masonry veneers should not be carried down over concrete foundations.
- Wherever possible, buildings should be designed with physical barriers to prevent termite access to the structure. Refer to Figures 1 and 2 and AS 3660.1.
- In areas where subterranean termites are prevalent, the level of risk of attack to buildings can be reduced by taking simple and inexpensive measures during construction; such as eliminating moisture traps and providing adequate ventilation in critical zones, (e.g. sub-floor areas) to enable timber to remain dry.
- Drainage (surface or sub-surface systems) should be provided to remove water and prevent ponding on the site; particularly with 'slab on ground' construction.
- Sites should be cleared of vegetation and ripped to remove roots etc. prior to commencing earthworks.
- Vegetation, tree stumps, and roots should be removed from site and not incorporated in any fill.

Prior to Construction

- Where termites are detected on site, they should be eradicated by a licensed pest controller. Site preparation and earthworks should, where possible, eradicate termite nests or colonies.

Whole Building Protection Systems

AS3660.1 provides a range of options for the protection of new buildings from subterranean termites. Figures 1 and 2 summarise these for timber floors and monolithic slab on ground construction respectively.

N.B: Where the concrete slab is not monolithic in accordance with AS 2870, full underslab chemical (reticulated in Qld) or physical barriers will be required.

Ant Caps (Termite Shields)

These are physical barrier systems that are inserted between the lowest floor framing timbers and the supporting stumps, brickwork, piers etc. They are usually formed from corrosion resistant sheet metal or mesh and are designed to force the termites out into the open and to allow physical inspection and simple, early detection and eradication of termite activity.

Concrete Slab Barriers

A good quality monolithic slab (no cracks or construction joints) designed and constructed to AS 2870 provides a physical barrier. Where construction joints or service penetrations occur, other forms of physical or chemical barriers must be provided. Exposed slab edges (min. 75 mm) around the perimeter of the building provide for physical inspection, detection and eradication.

Chemical Barriers

Chemical barrier systems provide a zone of treated soil, poisonous to termites, under footings and slabs and/or around the perimeter. Chemicals registered for termite protection include organophosphates and synthetic pyrethroids (modified). These chemicals have varied life expectancies (refer to product label & directions), depending on soil and exposure conditions, and **will** therefore require replenishment at regular intervals.

Reticulated Chemicals

Chemicals may require a reticulation system to permit retreatment in inaccessible areas, i.e. under slabs. This requirement is mandatory in Queensland. These proprietary systems use a piping and distribution network installed at strategic points under concrete slabs and around the perimeters of buildings. At completion of construction, chemicals are injected to reach each distribution point. Retreatment can be applied at any time.

Chemically Impregnated Membranes ('Kordon TMB')

Underslab and perimeter protection can be provided with a proprietary system where a vapour barrier membrane is laminated to a synthetic fibrous web impregnated with synthetic pyrethroid "deltamethrin".

Stainless Steel Mesh ('Termimesh')

This proprietary system consists of a fine woven marine grade stainless steel mesh used as a physical barrier. The stainless steel mesh is too small for termites to pass through and too hard to chew through. The mesh can be under the entire concrete slab or as a partial system in conjunction with a concrete slab barrier, that allows for construction of a perimeter barrier only, with sleeves and clamps to seal around service penetrations. The mesh can also be formed into 'socks' for stump/post applications. Installations must comply with the manufacturer's requirements.

Crushed Granite ('GranitGard')

This is a proprietary physical barrier system that can be used under slabs and/or around posts and footings. The barrier is comprised of finely crushed and accurately graded (screened) rock of particle

size and voids designed to prevent termite passage, i.e. voids too small to pass through and particles too large for termites to move. Crushed granite is not presently recommended for protecting buildings against *Mastotermes* spp. and should therefore only be used south of the Tropic of Capricorn. Installation must comply with the manufacturer's specifications.

Termite Resistant Timbers

The heartwood of many timber species (refer Table 1) has natural resistance to termite attack while the sapwood of others can be preservative treated in accordance with AS 1604 to "H2" level (or higher) to render them immune or resistant.

Timbers that are easily preservative treated include slash pine, hoop pine, radiata pine and Caribbean pine. The sapwood of termite resistant hardwoods can also be treated to render it immune to termite attack.

The use of highly resistant, durable timber or treated timber is recommended for timber stumps, building poles and landscaping timber in direct contact with the ground.

Preservative treatments can come in many forms including -
CCA Copper Chrome Arsenate
ACQ (Preserve) Ammonium Copper Quaternary
LOSP Light Organic Solvent Preservative (H3 maximum)

All these treatments are achieved with pressure impregnation. Brush-on treatments do not offer long term protection from termites.

Table 1 Termite Resistant Timbers

In-Ground and Above Ground ¹	Above Ground Only
red bloodwood grey box cypress forest red gum ironbark (all species) white mahogany Gympie messmate tallowwood turpentine slash pine ^{2/3} hoop pine ² radiata pine ² Caribbean pine ^{2/3}	blackbutt spotted gum red mahogany white stringybark

Notes:

- The sapwood of these species is to be treated to 'H5' level for in-ground use, 'H3' level for weather exposed above ground use and 'H2' level for fully protected, above ground applications.
- The heartwood of these softwoods is to be limited 20% of the cross-sectional area in all weather exposed applications.
- The heartwood of slash and Caribbean pine is considered termite resistant, and therefore does not need to be limited to 20% for fully protected, above ground applications.

During Construction

- Install physical barriers or chemical soil barriers in accordance with the BCA and AS 3660.1. Refer Figures 1, 2 and 3.

Notes:

- Chemical soil barriers must be installed by licensed pest control operators.
- Termimesh, GranitGard and reticulated chemical systems must be installed by licensed installers.
- As well as underslab treatment, AS 3660.1 also requires perimeter protection of the building which must be capped in Queensland.

- Ensure physical barriers are not damaged by various tradespeople.

- Remove all formwork, form boards, profiles, pegs, etc. near or under foundations or slabs. Vegetation and timber products should not be included in any backfill.

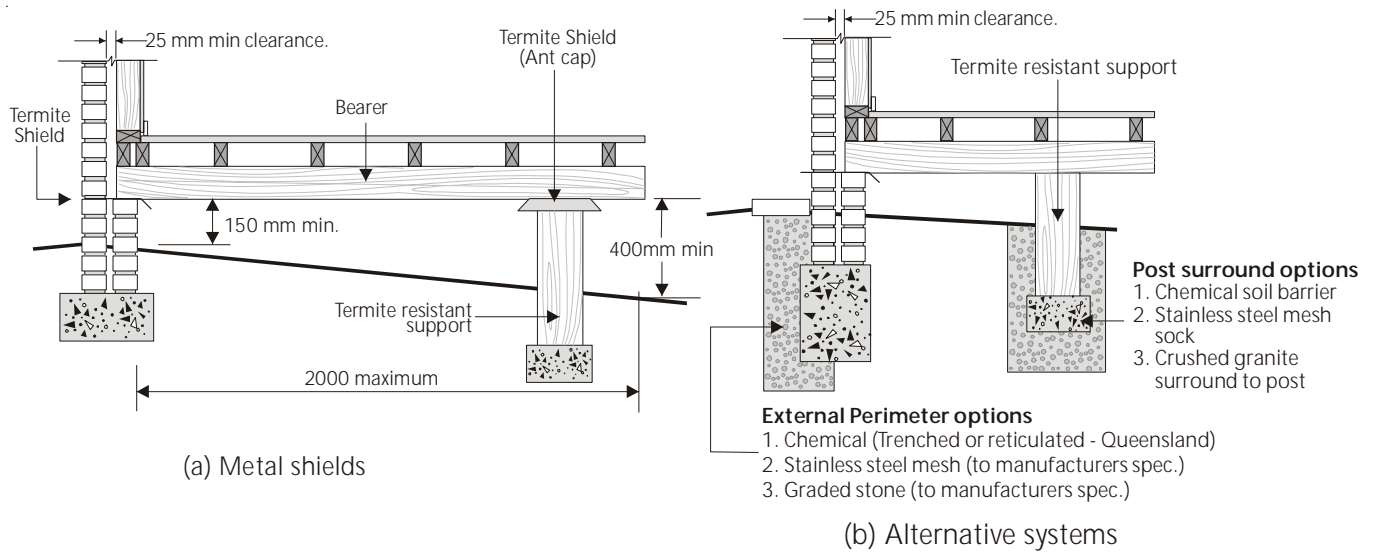

FIGURE 1 TERMITE BARRIERS FOR SUSPENDED TIMBER FLOORS

NOTE: All systems require regular inspections (not greater than 12 month intervals).

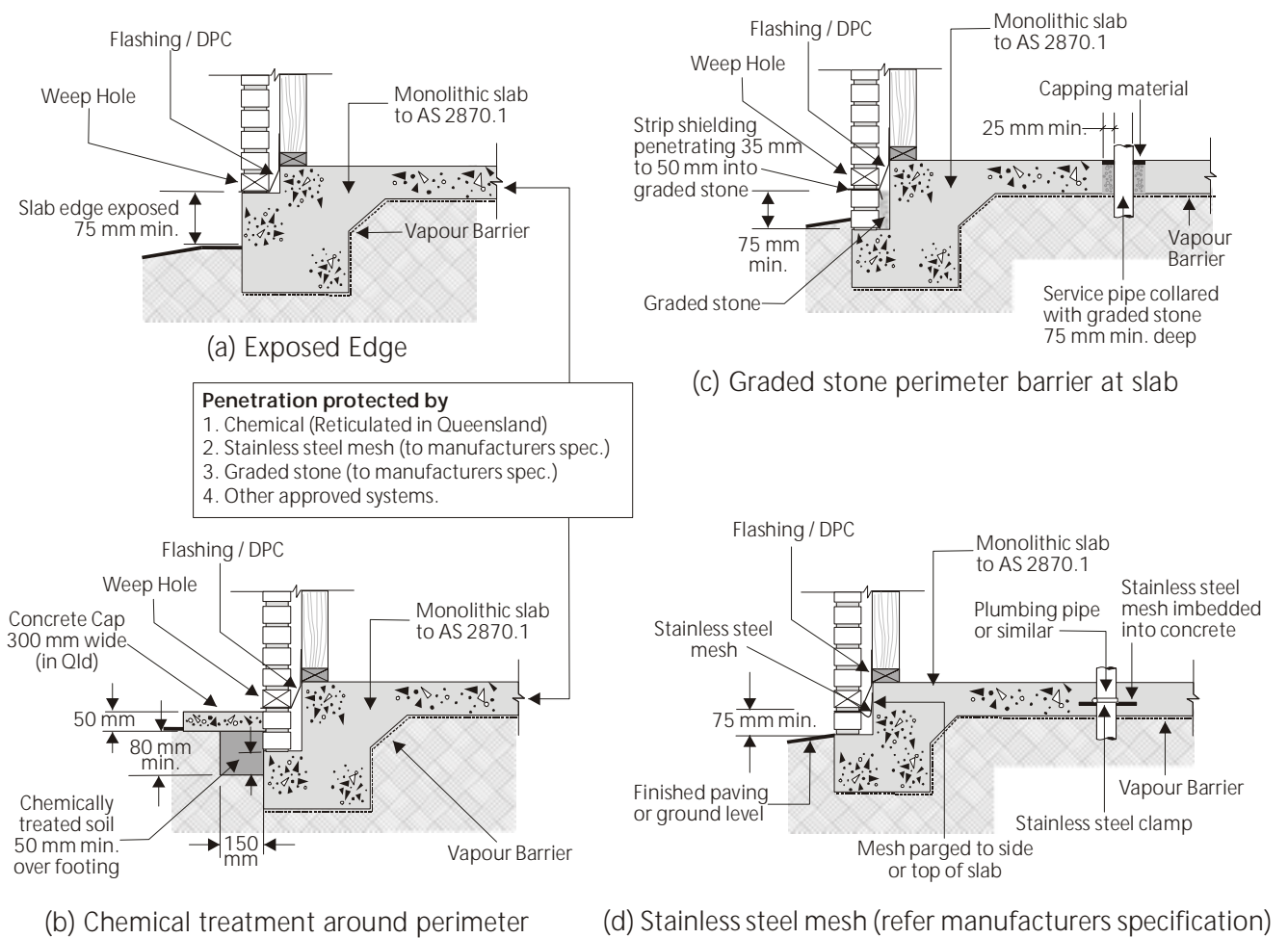
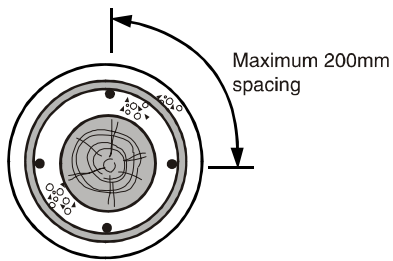
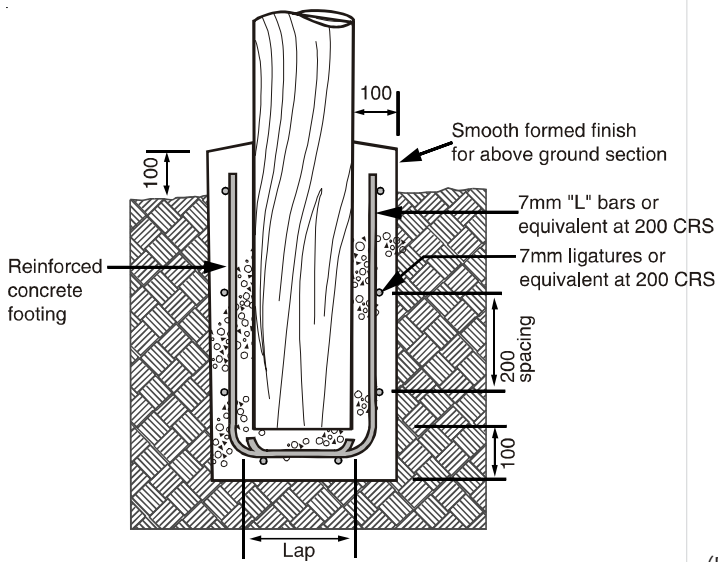

FIGURE 2 TYPICAL TERMITE BARRIERS FOR MONOLITHIC CONCRETE SLABS

NOTE: All systems require regular inspections (not greater than 12 month intervals).



(a) Reinforced concrete footing

Distance from Coast (km)	Minimum Concrete Strength (MPa)	
	Exposed portion	Embedded portion
0 - 1	40	25
1 - 50	32	25
>50	25	25

(Details provided courtesy of the Cement & Concrete Association of Australia.)

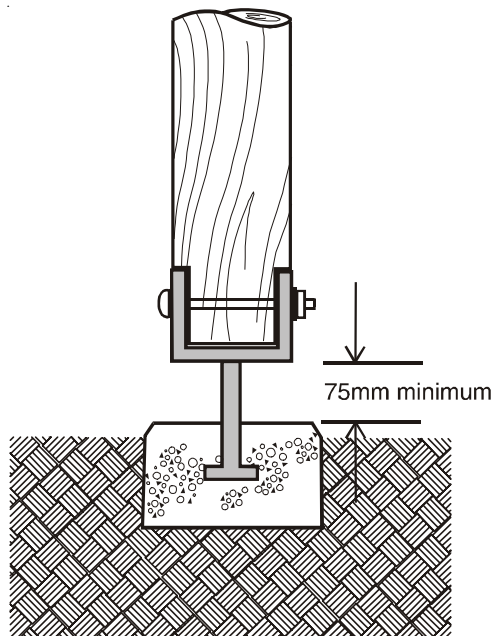

(b) Posts and poles on stirrups (AS 3360.1)

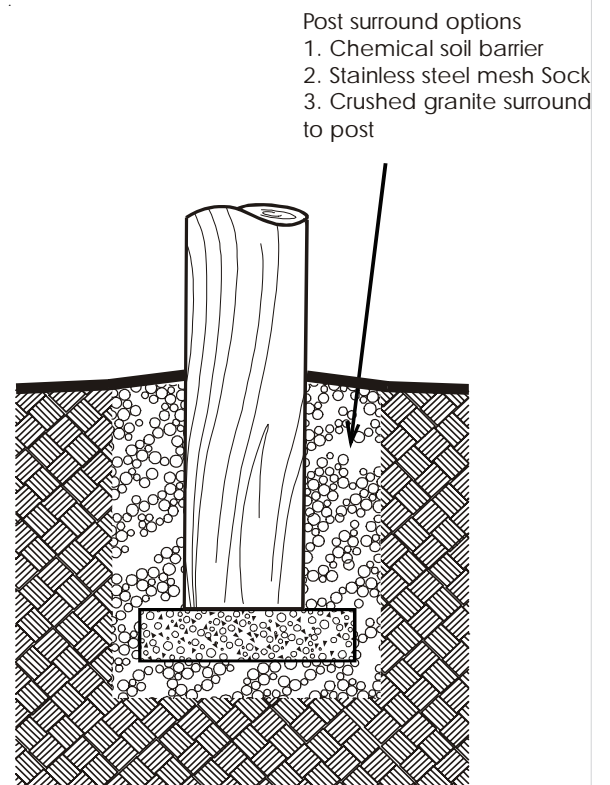

(c) Post surround options (AS 3360.1)

FIGURE 3 TERMITE BARRIERS FOR POSTS AND POLES

Note: All systems require regular inspections (not greater than 12 month intervals).

- Use termite resistant timber for timber in contact with the ground, i.e. Durability Class 1 timber or timber treated to "H5" level.
- Once formed, the barrier system should not be bridged or breached by construction, e.g. carports, paving, trellises, annexes, installation of underground telephone cables, landscaping or gardening. Where such projects are intended, or have occurred, action must be taken to maintain or to restore the integrity of the barrier system.
- Ensure weep holes or joints in brickwork are not covered by soil or other landscaping materials.

Post Construction and Maintenance

- Where landscaping or other site disturbances (new telephone cables, slabs, etc.) adjoining the structure breach the perimeter chemical soil barrier engage a licensed pest control operator to re-establish the barrier in accordance with AS 3660.1.
 - Have a licensed pest control company carry out annual inspections in accordance with AS 4349.3 to detect any termite activity.
- Annual inspection should at least include:
- * inspection around perimeter weepholes in brick veneer construction.
 - * inspection of landscaping timbers, fencing and other timber structures.
 - * inspection of termite shields ensuring they are in good condition and not breached by galleries.
 - * underfloor inspection of stumps, floor frame and perimeter masonry.

If termites are found, take remedial action in accordance with AS 3660.2.

- Search for and eliminate sources of persistent moisture or dampness within or near buildings.
- Inspections by licensed pest controllers should be supplemented by more regular inspections by the home owner at approximately 3 - 6 monthly intervals. If any unusual activity is noted call in a pest controller to identify and treat.

For further advice on inspection and remedial action, refer to AS 4349.3, Queensland Forest Service Timber Note 10 and Timber Facts Advisory Note No. 7.

NOTE: After the discovery of an active infestation, it is important that the termite workings are not further disturbed until the control approach has been determined.

Landscaping

- Landscaping elements should not breach or bridge physical or chemical barriers.
- Don't store wood or other organic material against buildings.
- Keep gardens and landscaping clear of weep holes and joints in masonry, physical barriers (ant caps) and damp proof courses.
- Conduct regular inspections to ensure the perimeter of the house is kept clear of organic material and kept neat and tidy.
- The perimeter area around buildings should be graded to drain away from exterior walls (refer AS 2870.1), and to divert stormwater from the building.
- Timber used in contact with the ground should be termite resistant.

Summary

Buildings can be effectively protected from subterranean termite attack. The level of protection provided and the associated risk will vary depending upon construction type, preventative measures taken and the level of regular inspection and maintenance.

Where there is a significant risk due to design, potential lack of maintenance/inspections, etc, termite resistant framing should be considered in addition to whole building protection to maintain structural integrity should infestation occur.

For further information:

Australian Environmental Pest Managers Association Ltd. Phone: 1800 252 772
Fax: (07) 5495 3196

TERM-guard Phone: (07) 3373 7788
Fax: (07)3373 8984

TERMI-MESH Phone:(07) 3875 2140
Fax: (07) 3875 2142

SlabSet Phone: (07) 5496 8918
Fax: (07)5495 6055

GranitGard Phone: (1800) 032549
Fax: (07)5559 0044

Kordon Phone: (0417) 362 488
Fax: (07) 5520 3033

The White Ant Com Phone:(07) 5524 9532
Fax: (07) 5524 8718



Timber Queensland Limited
ACN 092 686 756 • ABN 50 092 686 756
500 Brunswick Street, Fortitude Valley
Brisbane Queensland 4006
PO Box 2014, Fortitude Valley BC Qld 4006

Phone: (07) 3254 1989

Fax: (07) 3254 1964

Website: www.timberqueensland.com.au

Email: admin@timberqueensland.com.au

Whilst every effort is made to ensure the accuracy of advice given, Timber Queensland Limited cannot accept liability for loss or damage arising from the use of the information supplied.