

# Attached Carport

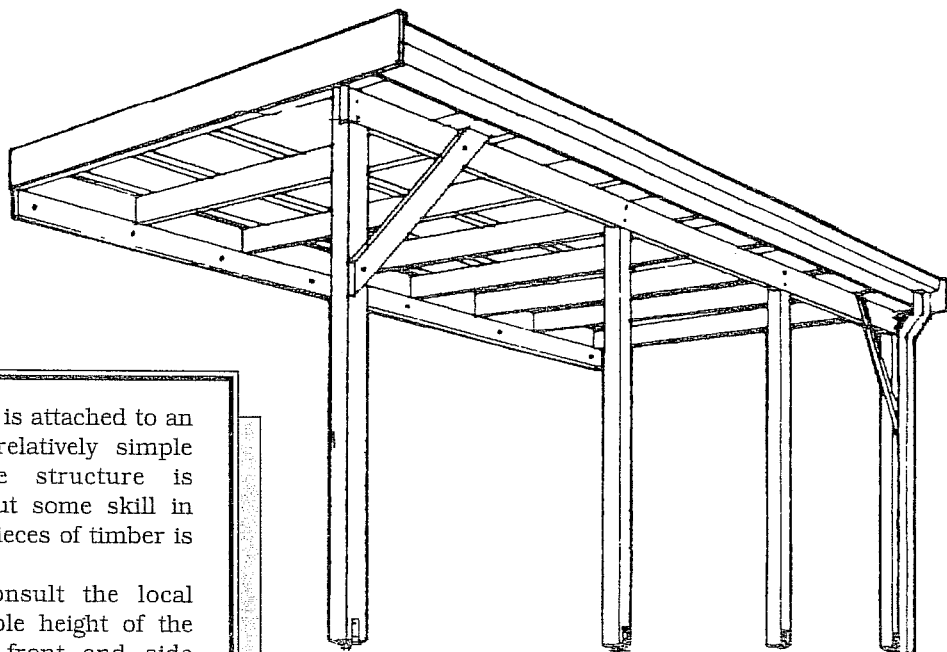

**B**uilding a carport which is attached to an existing structure is relatively simple because bracing of the structure is considerably simplified. But some skill in handling tools and larger pieces of timber is desirable.

Generally, you should consult the local council about the acceptable height of the structure, distance from front and side boundaries and other local regulations.

## TOOLS YOU WILL NEED

Saws - Hammer - Carpenter's Mitre Square  
Measuring Tape/Rule - String Line and Level  
(Plumb Bob would be useful) - Spirit Level  
Drill and Bits - Spanners - Tin Snips for roofing  
etc. - Masonry Drill (for brick wall fastening)

## MATERIALS YOU WILL NEED

### TIMBER

(softwood or hardwood)

100 x 100mm	(durable species required)* 4 pieces each 2.4m dressed all round DAR (for posts)
150 x 50mm	sawn timber 2 pieces 6.0m (beam and ledger) 8 pieces 3.0m (rafters)
200 x 25mm	primed fascia board 2 pieces each 3.3m (front and rear fascia)
100 x 38 mm	sawn timber 2 pieces each 1.2m (knee braces)
75 x 38mm	softwood roofing battens, sufficient for five (5) 6.0m runs along roof line.

### HARDWARE

7/125 x 9mm	galvanised coach screws, OR fixing ledger
7/100 x 12mm	galvanised expansion bolts to wall
8/100 x 9mm	galvanised round head bolts, nuts, washers (beam to post)
4/75 x 9mm	coach screws (knee brace to post/beam)
28	galvanised framing anchors (14 left, 14 right) with necessary flat head nails.*
4	post anchor bases or stirrups to choice to fit the 100 x 100m DAR (for posts)
50/75 x 3.15mm	bullet head nails (skew nailing rafters as required)
50/65 x 40mm	galvanised bullet head nails (fixing fascia)
50/75 x 2.8mm	flat head nails (fixing battens)

Recommended fastenings, galvanised, for post anchor bases or stirrups.\*

Roofing material to choice, in 3.0m continuous lengths.\*

Fastenings as recommended for roofing.

Roof guttering, 6.0m length, plus stop ends and downpipe as required.\*

Brackets and fixings for guttering, etc.

Barge moulding of zincalume 2/3.3m lengths

Flashing if required (carport roof to existing structure).

\*Consult your TABMA merchant for suitable available materials and how these can be ordered.

# DESIGN OF CARPORT

This design for a carport gives a covered area of approximately 6.0m long x 3.0m wide with the minimum under rafter clearance of 2.4m. Essential bracing front to rear is provided by diagonal or knee bracing while side to side bracing is achieved by firm attachment to existing structure.

This two-way bracing is required because the supporting posts are fixed to fabricated galvanised components (stirrups, angle or post anchor bases) which are available from many building material merchants.

Roofing material suggested is lightweight corrugated or other roll formed sheet zincalume or aluminium. This roofing should be fastened to the battens using the maximum number of fasteners as recommended for high wind areas by the manufacturer of the roofing material. For this reason the rafters are firmly fixed to beams and ledger using nails and standard galvanised framing anchors to each rafter/beam junction.

A general recommendation is that all timbers in the carport which are exposed to sun, and especially to rain or dew, should be given protective coatings (paints, stains or pigmented finishes) which should be maintained regularly.

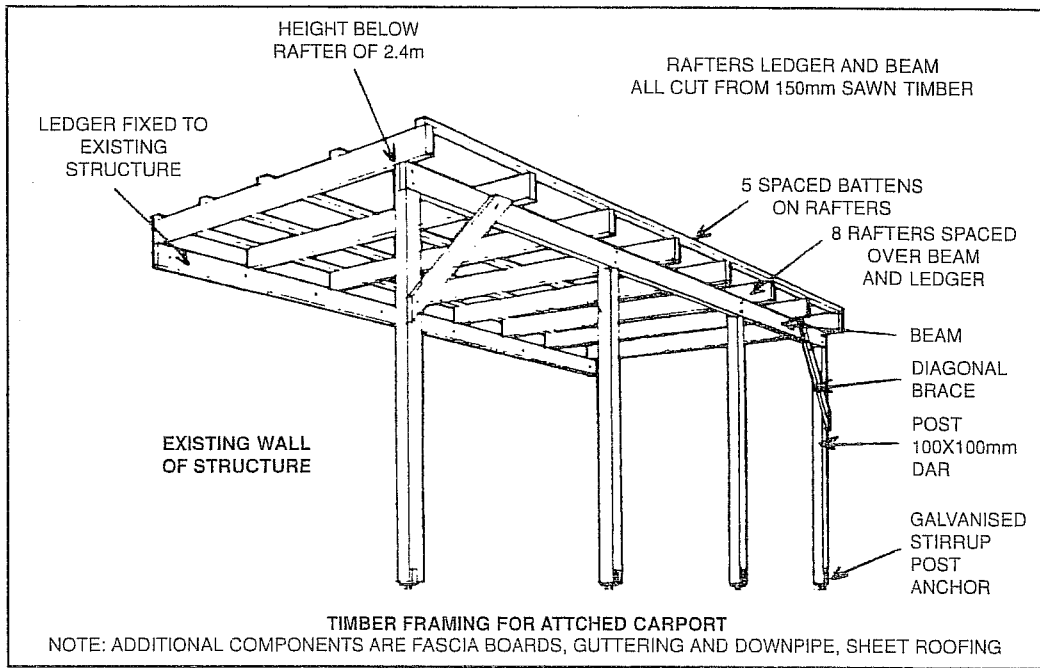

## ▼ STEP BY STEP ▼

**1 WHERE TO BEGIN.** Laying out site: The site on which the carport is to be located is assumed to be level. Fix the centrepoint of the posts as a first step to putting down foundation blocks of 300 x 300mm (or larger) concrete blocks onto which the post stirrups or anchor bases are fixed.

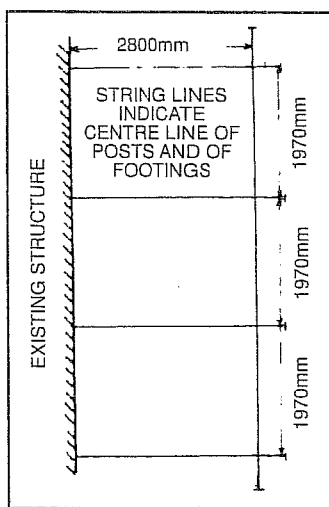
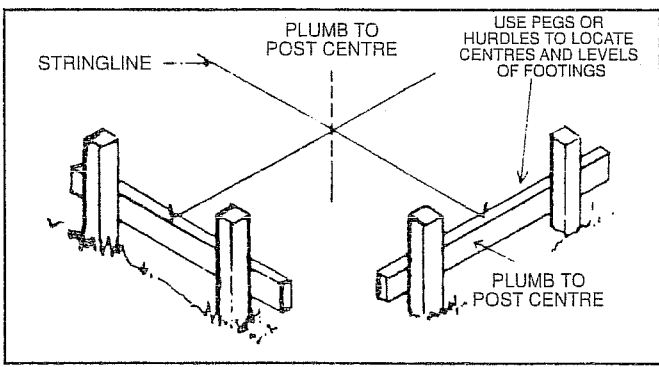

Using a string line, line level, etc, and the necessary pegs or hurdles, lay out the carport as below, clearly establishing where and at what height the post footings can be poured to give uniform levels for fixing post supports.

**2** Dig 300 x 300mm holes, fit formwork if needed, then pour concrete for post footings with the post anchor bases exactly in place on the proposed centreline. Allow one week for concrete to harden before proceeding with next step.

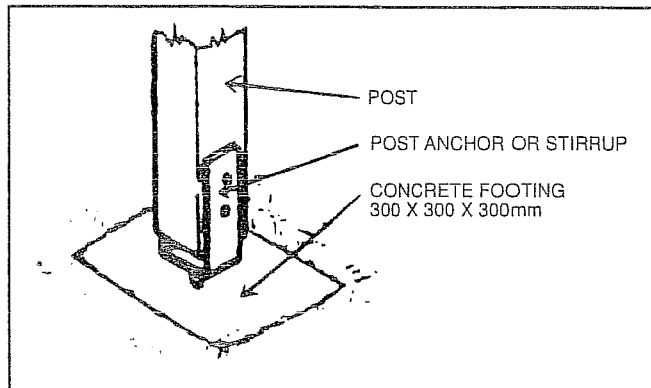

**3 CUT FOUR POSTS 'A' each at least 2.4m long, from the timber pieces ordered 100 x 100mm x 2.4m DAR. Plane or sand off sharp edges.**

**4 ERECT POSTS.** Along the outer side of the carport erect on each post anchor or stirrup, the posts cut in Step 3. Temporarily fix posts but use braces to erect the posts vertically (but temporarily). Fix all bracing no higher than 1500mm above post bases.

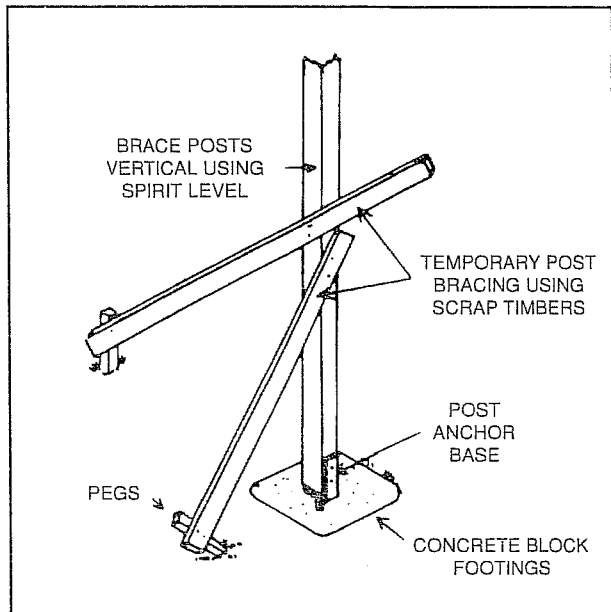

**5 MARK POST HEIGHT.** Commencing with front post, mark 2.4m above final ground line and using string line and line level mark similar horizontal height on the other four posts. (Note that in this carport design both beam and ledger are installed horizontally.)

**6 CUT HOUSING FOR BEAM.** Demount posts and cut full housing for 150 x 50mm x 6.0m beam in each post. Cut off excess post length at the 2.4m line described in Step 5.

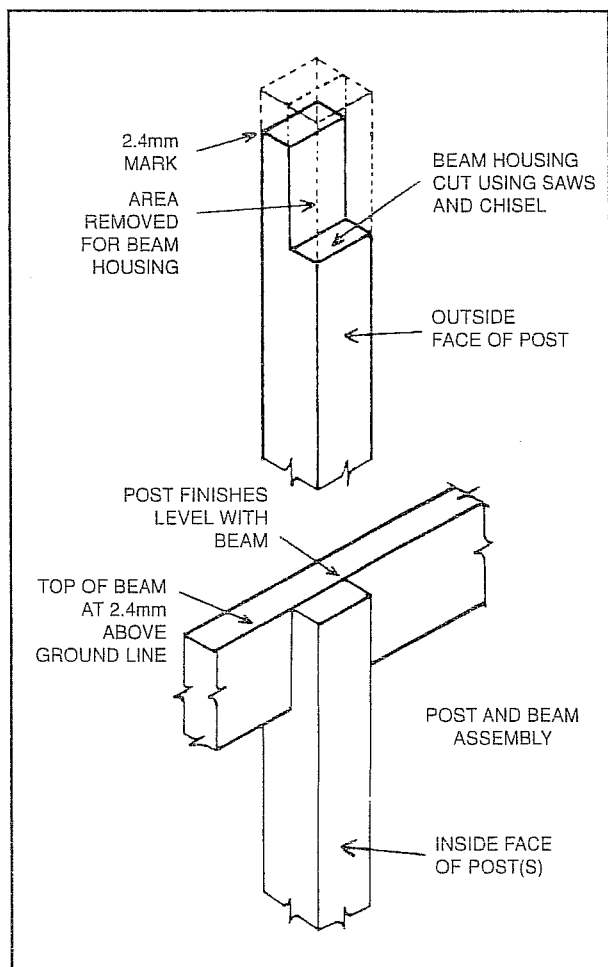

**7 RE-ERECT POSTS.** Erect posts on bases, firmly fixing posts on bases and to temporary braces.

**8 CUT AND FIX BEAM.** With posts erected and re-braced, beam can be cut to 6.0m length or to a length to fit flush with outer faces of front and rear posts. Mark out and drill bolt holes in beam on centre line of each post which should be as indicated in diagram below. Locate beam on posts. Temporarily nail fix in position, then drill holes through posts using beam holes as guide. Firmly bolt beam into place using two 9.5mm bolts at each post.

#### MARKING OUT BEAM

\*N.B. CHECK MEASURE LOCATION OF POST CENTRE LINE AND CONFIRM THAT THESE MEASUREMENTS SUIT YOUR JOB.

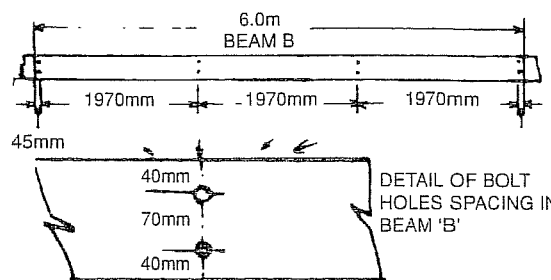

**9 CUT AND FIX KNEE BRACES.** Cut two knee braces from the 100 x 38mm x 2.4m as sketched below. (Fit knee braces to the outside of posts and beam.) Fix knee braces to front and rear posts using nails and reinforce nailing with one coach screw at each fixing point.

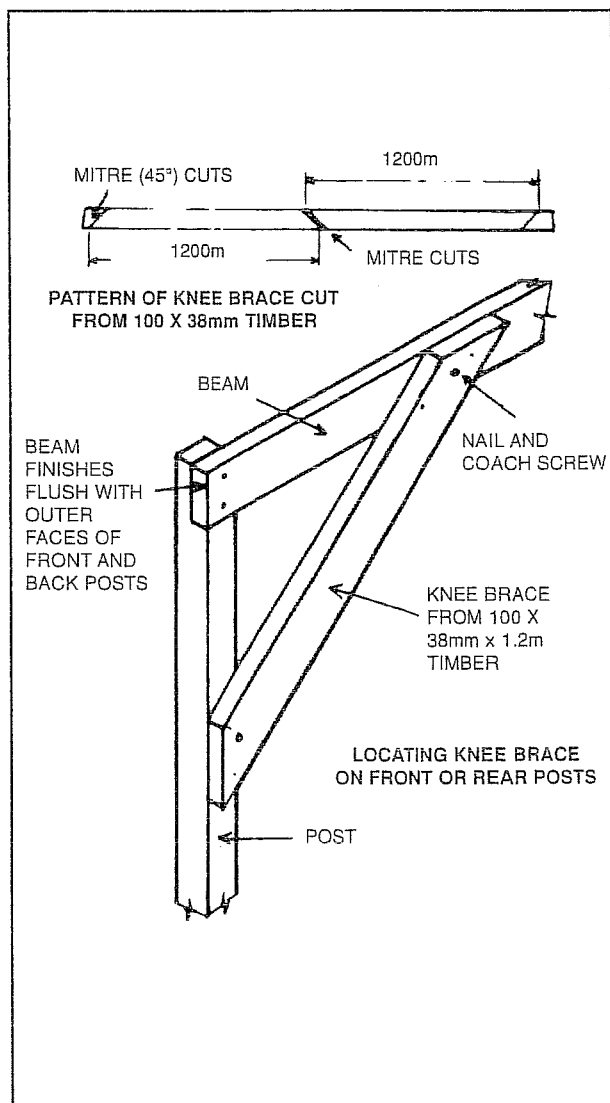

**10 CUT AND FIX LEDGER.** From a remaining timber piece 150 x 50mm x 6.0m cut a ledger 6.0m long. Using string line or rafter and spirit levels, locate position of upper edge of ledger on existing wall lined up horizontally (and parallel to beam) but at a height at least 50mm above upper edge of fixed beam to allow for roof slope. Mark ledger line and location along existing structure using a string line and level.

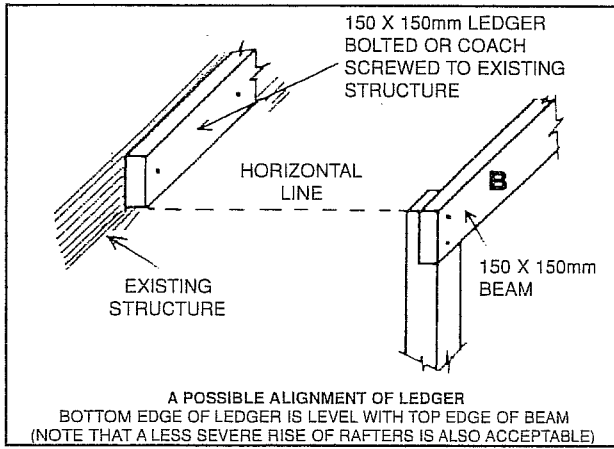

**11 FIX LEDGER TO WALL.** Locate necessary positions of coach screws or expansion bolts and drill required holes in ledger and existing structure. Fix ledger in place.  
**Note:** Where appropriate fix ledger to stud wall at each second stud OR to a brick/masonry wall at up to 1m centres.

**12 CUT RAFTERS AND FIX.** From the timber pieces 150 x 50mm, cut eight rafters 150 x 50mm x 3.0m and commence fixing to beam and ledger, spacing out evenly over the length of beam and ledger. Fix front and rear rafters first and check distance between ledger and beam. Skew nail rafters in place then reinforce nailing using framing anchors. Note that rafters project beyond beam by about 200mm.

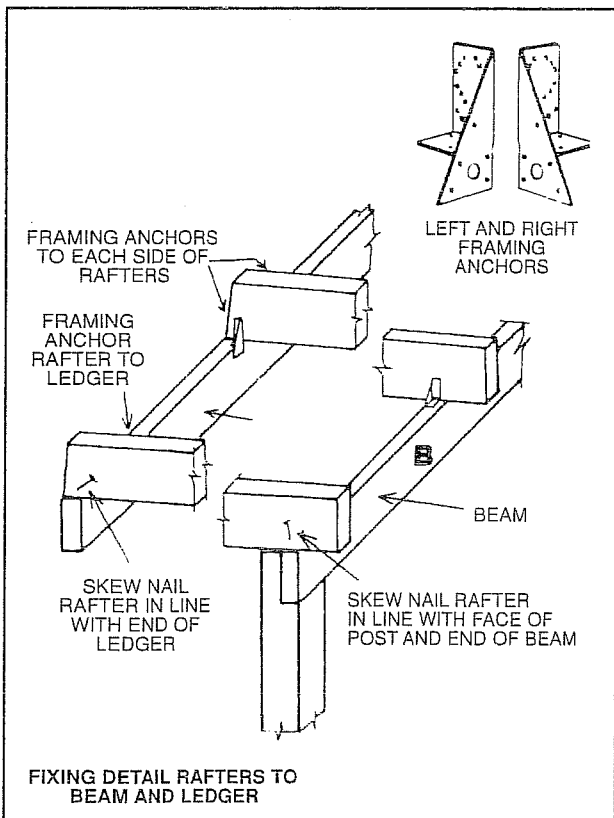

**13 TRIM RAFTERS.** Trim rafters to allow roofing sheets to project 50mm beyond rafter ends (this should mean a wall to rafter end distance of 5950 mm). Trim off all rafter ends vertically using string line and plum bob or spirit level to indicate cutting line.

**14 CUT AND FIX ROOFING BATTENS.** Cut and fix five battens to run along 6.0m length of roof from outer faces of front and rear rafters. Evenly space battens over rafter length but locate battens at ends of rafters.

**15 CUT AND FIX 200mm FASCIA BOARDS.** Cut two lengths of fascia to fit along front rafter and along rear rafter. (**Note:** Fascia could be fitted to project beyond end of rafter to conceal guttering if desired.) Fix fascia in position so as to cover exposed long edges of selected roofing.

**16 CUT AND FIX GUTTERING AND DOWNPIPE.** (if required). Fix guttering brackets, etc to both rafter end and to battens, and install guttering and downpipe.

**17 FIX SELECTED ROOFING** (as required). (**Note:** Before installing roof sheets, a flashing between existing wall and roofing is frequently fitted so as to prevent rain water running down existing wall). Use maximum fastenings as recommended by the manufacturer to fix roofing sheets.

**18 FIX BARGE MOULD** to front and rear fascia.

**19 REMOVE TEMPORARY BRACING.**

**20 FINISHING.** Finish all exposed timber with protective and decorative finishes as recommended by the coating manufacturers. Paint barge mould and guttering as desired.

Supplied by