

## Local Government Approvals

Construction of outdoor works such as a deck, a pergola, garden sheds, fences etc., will probably need approval by your local authority and we recommend that your Local Councils be consulted early before detailed planning is commenced. Obtain from Council Officers any information about relevant regulations, the number of and detail required on plans, scale of drawings and what permits (e.g. owner-builders permit?) are required before work commences.

## Timber Species Selection

A typical carport roof system will have most of the timber framework protected from weather by the roof covering itself. However, detail design and protective coatings should provide protection for the end grain of rafters and beams. Thus for the main roof structure any structural grade (stress graded) of timber could be selected.

For those timber components of the carport which are fully exposed to the weather, you should be more selective and order from species which could be expected to be ranked "durable" or "moderately durable", or products which have been preservative treated at least to hazard level 3 (H3). Thus, the 6 posts in the sample design of this project would require some selection. See notes under Tables 1.

Consult your TABMA Timber Merchant about available, suitable timbers particularly stress grades, species and branding/grading of preservative treated (plantation) pines.

## ▼ STEP BY STEP ▼

**1 Prepare site:** -The site on which the carport is to be located is assumed to be level ready to accept the pouring of the working area slab i.e. formwork is in place providing for a relatively level slab from which water will run off.

The timber carport, whether attached to the house or free-standing is a relatively simple structure similar to a covered pergola in Handyman Project Number 28. That is, a carport is supported by posts, poles or piers/columns, the cover is supported in turn by beams, rafters and perhaps roofing battens and the whole **MUST** be fixed together to resist wind forces expected in the area. Wind forces will tend to push the structure sideways (lateral forces) and to lift up the roof and attached members (uplift forces). For the first named, bracing must be built into the design. For uplift forces, all fasteners (bolts, nails, nailing plates, stirrups, etc.) must together provide strong attachment from the roofing material itself down to the foundations.

**2 Laying out site:** Two alternative procedures could be considered.

- A Using string line, line level etc. and the necessary pegs or hurdles locate the position of the post footings prior to pouring the concrete. Remove string-lines etc. pour and consolidate the concrete then while concrete is still wet, insert the selected post bases in the planned position using the string lines once again, or

### **SPECIAL NOTE** about ATTACHED Carports

*Where a carport (or a pergola is to be attached to another structure, such as an existing (or a new) house, it is obviously necessary to verify that the supporting structure is capable of supporting (and bracing) the new carport or pergola. In particular that the point(s) of attachment are capable of supporting both the extra load and possible uplift forces.*

*Where it is proposed to provide attachment to roof fascias, it is necessary to confirm that the fascia itself is of adequate structural strength and adequately attached to the roof rafters.*

*Further, in the particular case of modern trussed roof systems, it is essential to obtain expert advice about the capacity of the (existing) roof trusses (to which its fascia is fixed) which will verify if such trusses can support the proposed extra loading.*

## Tools you will need

- Saw
- Hammer, nail punch
- Measuring Tape/Rule
- Carpenters metre square
- Tin snips (for roofing materials)?
- Spanners
- String line & line level
- Drill and bits
- Pencil
- Spirit Level

## Materials you will need

### TIMBER (softwood or hardwood)

- Posts** see Table 1 for cross section. Lengths to 2400mm, 6 required.
- Rafters** see Table 2 for cross section. Lengths depending on design including overhang. Number depending on spacing of up to 900 or up to 1200, as required for roofing material.
- Beams** see Table 1 for cross section. Lengths to be continuous to say 6.3 m depending on design 2 required.
- Fascia** 200 x 25 mm primed fascia 2 pieces 6.3 m, 1 piece 3.6 m.
- Bracing** 100 x 50 mm nominal 8 required. approximately 1.2 m long Temporary bracing-scrap timber 75 x 25 mm Hwd to requirements.

### HARDWARE

- Bolts** posts to beam 12/10 mm diameter. Length to design requirement.
- Framing Anchors** rafters to beams 2 left, 2 right hand for each rafter plus recommended nails
- OR**
- Joist Hangers** 2 per inner rafters to your design.
- Post anchor bases or stirrups** 6 required plus required bolts/nails/etc. to fix to post and to foundation slab.
- Nails** bullet head nails 75 x 3.15, 100 x 3.15 for general work\* but flat head nails, recommended for softwoods\*.  
\*nails exposed to weather to be hotdipped galvanised.
- Roofing** to choice, but must be in continuous length because of low roof slope. Length to design but allow 50 mm overhang to gutter end. Consult supplier about recommended maximum (high wind) fastenings - number, placement and type.
- Barge moulding** preformed barge moulding for front & sides to suppliers recommendations.
- Timber paints for exterior application for the system (primer/undercoat/finish) as recommended by paint manufacturer.
- Metal paints as recommended by paint manufacturer.

- B Pour concrete, consolidate the concrete smooth etc, and allow to cure. When cured, drill out on planned position, the holes to receive the post base bolts or fasteners as advised by the manufacturer.

### Special Note

For carports which will NOT be attached to a concrete foundation slab (i.e. posts or block footings) specialist advice should be obtained so that adequate resistance to wind uplift is provided by your footing system.

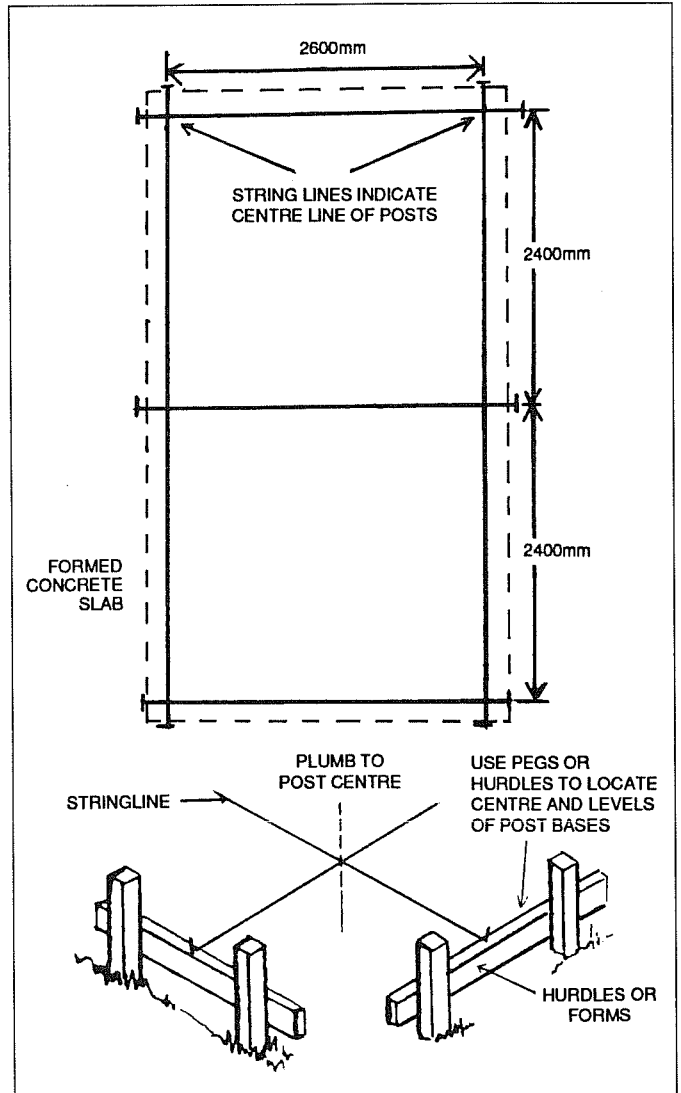

- 3** Cut six posts 'A', each 2400 mm long from the timber pieces ordered 100 x 100 mm x 2400 mm DAR or equivalent.

- 4** Erect posts: Along one of the sides of the carport erect each post on post anchors temporarily fixing posts into base as instructed by manufacturer (i.e. if nails are used as fasteners, leave heads of nails protruding so that they can be removed as required later) it is necessary to strongly brace these posts in a vertical position using scrap timber and spirit level etc. as required. Fix all bracing no higher than 1500 mm above post base.

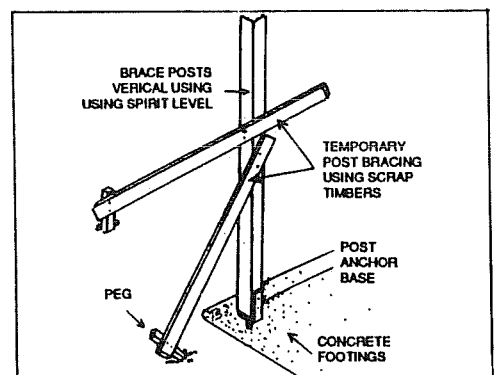

**TABLE 1**

**TYPICAL MINIMUM SECTION SIZES FOR POSTS IN 6m x3m. Carport as illustrated in Fig.1. below**

TIMBER SPECIES(1)	Post	Beam (2)
	Post Height 2400	N.B. for beam continous over 2 spans of 3m each and with single span rafters up to 3 m
Hwd F8 unseas.	100x100	200x50
Cypress F4 unseas.	100x100	200x75
PT Pine F5	90x90	240x45
U/T Pine F5		240x45
Oregon F5 unseas.	100x100(3)	200x75
Source:	Table 54 NSWTFM	Table 53 NSWTFM

(1) Abbreviations used are

- Hwd F8 unseas:** Native Hardwoods or equivalent, minimum stress grade F8, unseasoned, nominal size.
- Cypress F4 unseas:** Native cypress pine, minimum stress grade F4, unseasoned, nominal size.
- PT Pine F5:** Preservative treated plantation pine, treated for Hazard Level 3 (H3) or better, seasoned and stress graded to minimum of F5, finished size.
- U/T Pine F5:** Not treated plantation pine, stress graded as minimum F5, sizes given are usually finished sizes
- Oregon F5 unseas:** Sawn Oregon from North America or New Zealand, minimum stress grade F5 unseasoned - use with protection in weather exposed locations.

(2) Beam may be assumed to be protected by detailing and fascia and by regularly maintained paint coatings. Because of this protection, the beams should be at no hazard from rain and associated moisture/water absorption and consequently any structural quality timber could be selected. See also (3)

(3) Posts that are exposed to weather (sun, dew and rain) are consequently at risk of absorption of water and associated risk of decay. It is good practice, even with durable timber, to provide protective coatings to all timber surfaces but untreated radiata/slash/hoop pine should NOT be used for posts. Oregon may give good service if selected as relatively free of knots and gum/resin veins AND then adequately protected in all weather exposed areas, particularly in the end-grain, by protective coatings which should be regularly maintained.

(4) NSW Timber Framing Manual (NSWTFM).

**TABLE 2**

**TYPICAL MINIMUM SECTION SIZES OF RAFTERS IN 6m x 3m Carport as illustrated in Fig. 1. below**

N.B. Single 3 m span, sheet roofSource NSWTFM

TIMBER SPECIES(1)	RAFTER SIZE		Typical overhang of 450 mm would be acceptable. If greater overhang is desired see Tables NSWTFM
	Rafter spacing (3)		
	900	1200	
Hwd F8 unseas.	125 x 38	125 x 50	
Cypress F4 unseas.	150 x 38	150 x 50	
PT Pine F5	140 x 35	170 x 35	
U/T Pine F5(2)	140 x 35	170 x 35	
Oregon F5 unseas(2)	125 x 50	150x 38	
Source:	NSWTFM	NSWTFM	

(1) See explanatory Notes Table 1.

(2) These low durability timbers should be fully protected by detailing such as fascias, roofing overhang hence are acceptable in this particular application.

(3) Verify required spacing for specific roofing materials.

**CARPORIT FRAME SHOWING TIMBER COMPONENTS**

- A - POSTS
- B - BEAM OVERHANG
- C - MAIN BEAMS
- D - KNEE/CORNER BRACING
- E - RAFTERS
- F - FASCIA BOARD

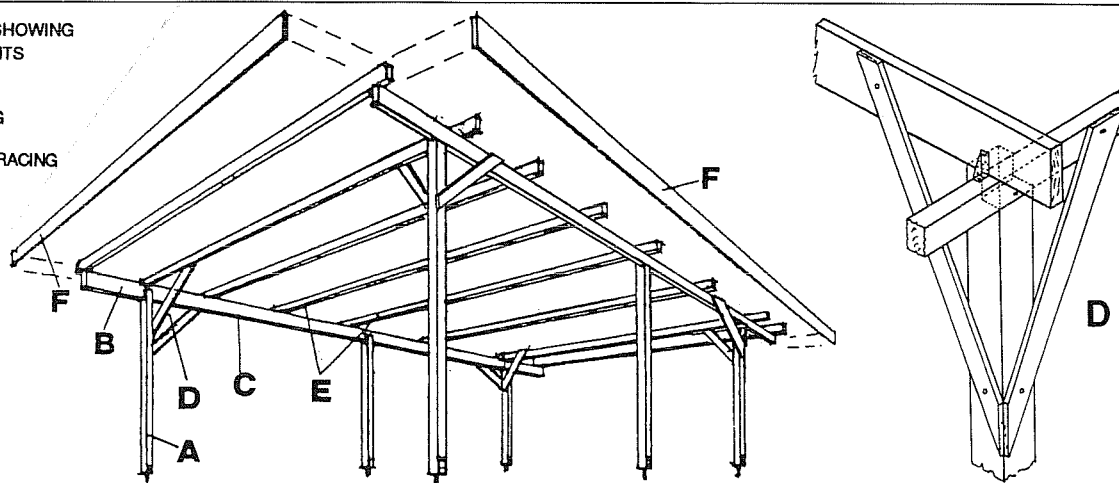

**5 Mark height:** Check horizontal alignment of top of each of three side posts, or mark 2.4 m height above ground level on front post and with string line mark the remaining posts to give horizontal line 2.4 m above base line.

**6 Mark roof slope:** Using straight edge such as the uncut beam, or more easily a string line, mark the angle of roof beam on top of posts allowing a 50 mm fall from front face of first post to rear face of rear post. In a similar way mark second line distant from first line equal to depth of beam. These marks establish slope of carport roofing using continuous sheet material and indicate cutting line for height of post and for housing of beam into post.

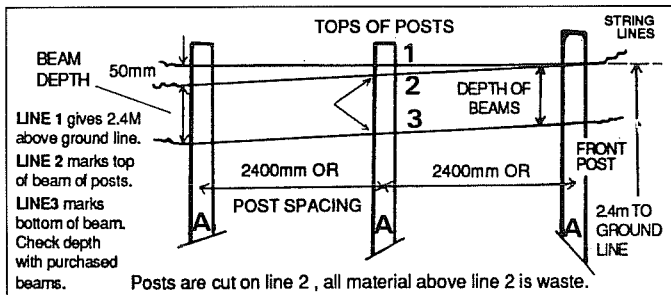

**7 Cut post housing:** Is-assemble posts from supports and braces then cut housing to allow beam to fit flush with the face of the post. Prime/seal housing with selected primer/stain, in the particular case of preservative treated timber use a recommended preservative solution to re-seal the cut section. Also prime seal as necessary post ends at this time.

**8 Fix posts:** When primer/sealer is dry, re-erect posts on bases/stirrups and brace as before. Locate beams in place, temporarily nail in position to your design. Drill holes for bolts through post and beam (2 bolts per post, insert bolts and tighten nuts (over washers).

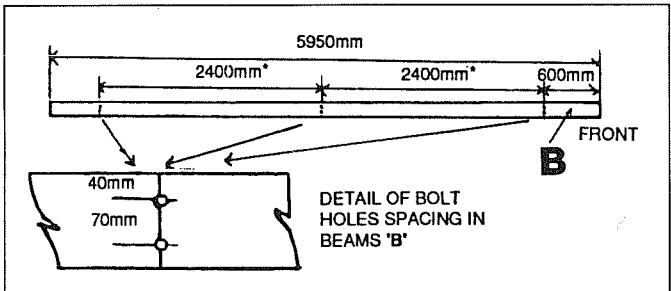

**9 Cut and attach angle bracing** to 4 outside (front and back) posts and to beam using nails and/or nailing plates/metal connectors.

**10a Fit rafters/rear rafters:** Depending on design, locate and fix in position the joist hangers for all the inner rafters (the two end rafters would be nail fixed to ends of beams).

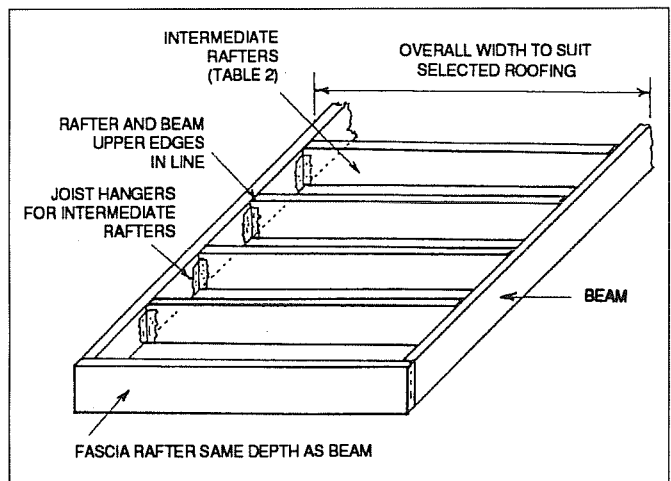

**10b** Measure up for front and rear rafter and cut to size and fix in position on beams. Again depending on your design, these pieces of timber could be "standard" rafter depth or equal to the depths of the beams. Use skew nailing if appropriate on "standard" rafter or preferably use framing anchors (which provide better hold-down).

**11 Fit bracing:** Measure up for bracing rafters adjacent to posts if designed (NB if your carport is attached to an existing building this bracing rafter and attached bracing may not be necessary). Fix bracing rafters (front and rear) and attach angle bracing to each of 4 corner posts and to the bracing rafters.

**12 Fit rafters:** Continue with measuring up (at this point you can correct straightness of beam by positioning rafters), cutting and fixing remaining rafters. (N.B. you may prefer to cut oversize overlength rafters and to later cut off to stringline running from front to rear.

You may use Rafter spacings nominated in Table 2 provided these are right for your selected roofing material.

**13 Fit trimwork/ Fascia:** Fix 200 mm wide fascia boards to front rafter and to the rafter ends allowing projection above rafter line as required for selected roofing material. Mitre joint at front corners.

**14 Fit guttering:** Cut and fit a rear fascia if desired. Attach rainwater gutter and downpipe as required directly to rafter or fascia.

**15 Fix roofing:** Install the selected roofing material directly to rafters and as instructed by the manufacturer using maximum recommended number of fastenings. Design should allow 50 mm approx. projection of roofing beyond last rafter over guttering).

**16 Fit barge mould:** Fix selected barge moulds to front and sides.

**17 Apply finish:** Finish all exposed timber and barge moulds with selected paints, etc. paying particular attention to exposed end grain.

**Disclaimer:** While the Timber and Building Materials Association (NSW) Limited (TABMA) and its members believe this publication is an invaluable guide to this project, the Association cannot guarantee that every statement is without flaw. Therefore, the Association and its members hereby disclaim all liability for errors or omissions of any kind, whether they be negligent or otherwise, or for any loss, damage or other consequence which may arise from any person relying on information stated in this publication.

This brochure was prepared with the assistance and co-operation of the Timber Development Association NSW Ltd.

For further advice telephone the

TDA Timber Advisory Service on (02) 9360 3088

Copyright Owner: Timber and Building Materials Association

**Supplied by**