

Planter Box and Trellis

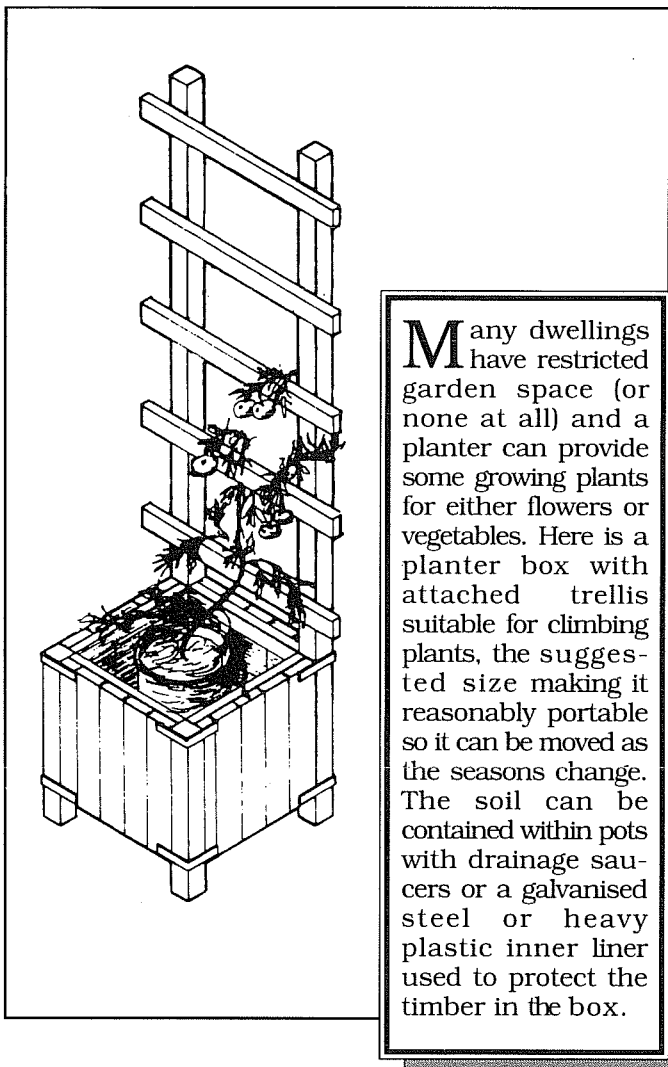

Many dwellings have restricted garden space (or none at all) and a planter can provide some growing plants for either flowers or vegetables. Here is a planter box with attached trellis suitable for climbing plants, the suggested size making it reasonably portable so it can be moved as the seasons change. The soil can be contained within pots with drainage saucers or a galvanised steel or heavy plastic inner liner used to protect the timber in the box.

STEP BY STEP

1 Cut trellis posts: From the two pieces 50 x 50mm x 1.8m DAR cut two trellis posts, 'P' each 1750mm in length.

2 Mark and cut trellis posts as shown in diagram. Mark out the two posts together (i.e. side by side) so that when the cross bar lines are marked they should line up accurately.

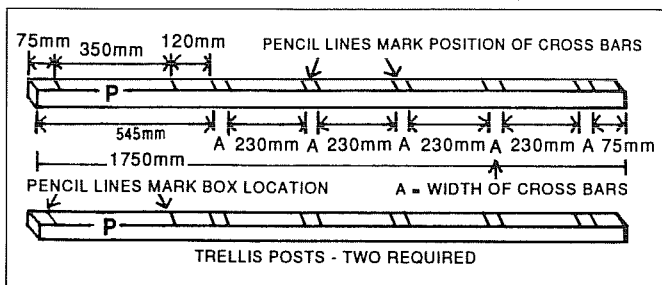

3 Cut front posts: From the timber piece 50 x 50mm x 0.9m DAR cut two front posts each 425mm long.

4 Cut side boards: From the pieces of 100 x 25mm DAR cut the suggested 20 pieces each 350mm long. (Or cut necessary pieces from the alternatives such as 75 x 25mm T & G Flooring). Round off all edges with sander, plane or sandpaper block.

5 Cut side rails: From the pieces of 50 x 25mm DAR cut eight lengths of rail, equal to the overall width of five side boards as cut in Step 4 (see Step 7). **Note:** Each of the side rails (and side assembly) must be exactly the same length, otherwise the box will not be assembled square.

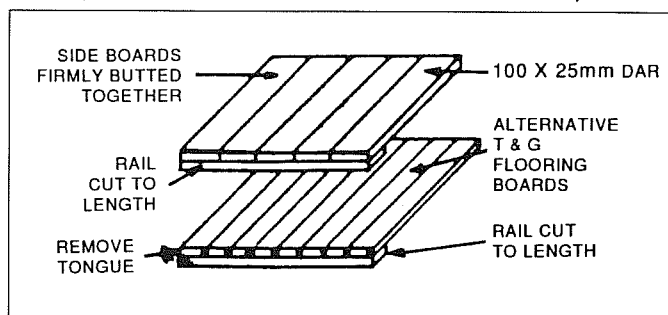

6 Apply first coat of primer or exterior grade stain or coating, as selected, to all the parts now cut. Allow this to dry before proceeding.

7 Assemble side panels: Make up four side panels as sketched, using two galvanised nails in pre-drilled holes at each rail/board junction. These side assemblies must be squared and of equal overall dimensions.

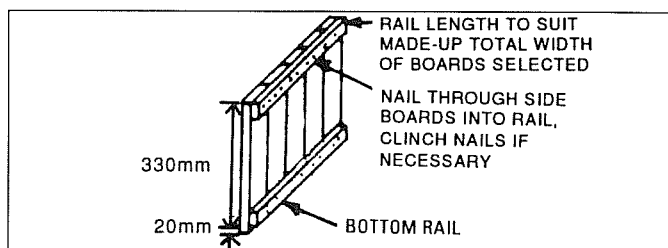

8 Fix angle brackets: Attach angle brackets to each post at spacings shown. Note that these brackets are visible on the **outside** of planter box. Several types of galvanised (or brass) brackets are available. You may need to drill supplementary holes in some of these brackets to position screws so that adequate fastening is obtained. It is desirable that each bracket be fixed to the **posts** with at least one screw on each face (i.e. two screws) and to each of the adjacent side assemblies also with two screws. Round off corner of posts sufficiently to permit the bracket to fit closely.

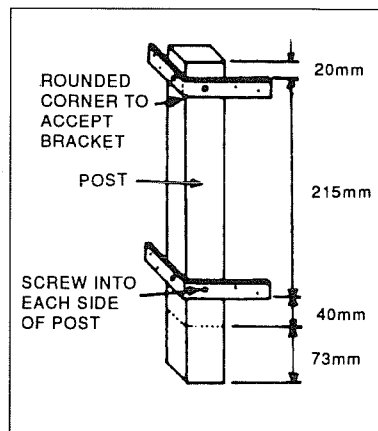

Tools you will need

- Saws
- Measuring Tape or rule
- Carpenter's square and pencil
- Woodworker bits (high speed steel bits may be needed to drill additional holes in corner brackets)
- Sander/plane/sandpaper
- Hammer
- Drill
- Screwdriver
- Chisel

Materials you will need

TIMBER

Selection:

Timber selected should be **durable** species. If the box is to be used fully exposed to weather and in-box plantings are proposed, timber should be **very durable** grade. **Consult your timber stockist about the durability of the readily available timbers.** If the planter box is to be used indoors only and plantings are in pots, etc. then a wider range of

HARDWARE

40 x 2.5mm Galvanised bullet head nails (for sides)
 50 x 2.8mm Galvanised flat or bullet head nails (for bottom)
 50 x 8gge Galvanised wood screws (for cross bars) countersunk or roundhead
 100 x 100mm Galvanised angle brackets with the required number of galvanised countersunk head or roundhead screws up to 30mm long.

9 Fix panels to brackets:

Commence by fixing the rear panel to each of the trellis posts, then the side panels to posts, then panels to front posts and concluding with fixing the front panel. Pre-drill screw holes but aim to keep the whole assembly square as a s s e m b l y proceeds.

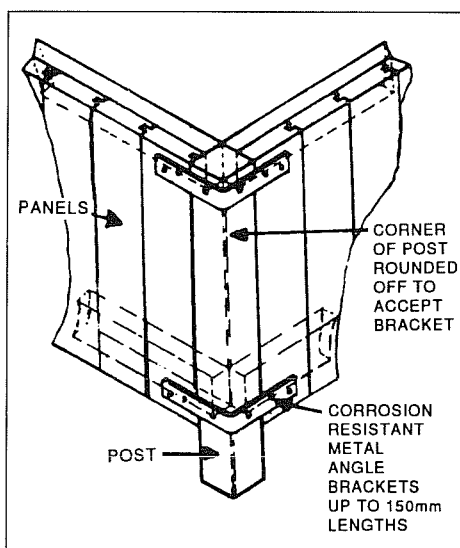

10 Cut floor boards:

With the assembled unit lying flat on a flat working surface, measure the length of flooring board(s) required and cut five 100 x 50mm DAR pieces to fit. The two outer floor boards are then notched to fit around corner posts. **Paint floor boards** with selected protective coatings or with first coat of finishes as selected, particularly any end grain.

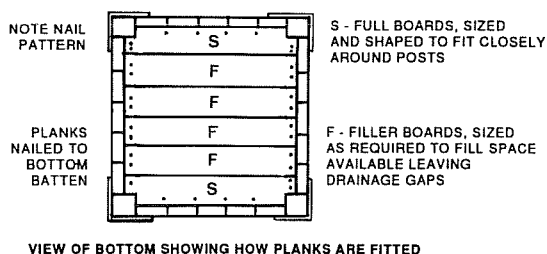

11 Fix floor boards:

First fix each of the two outer floor boards to the underside of both rails on which they will bear using two 50 x 2.8mm galvanised nails on ends and four nails on long side. Pre-drilling nail holes is strongly recommended. These two boards should be fixed so that the unit is squared up and adequately braced (see Step 10 diagram).

The remaining floor boards can then be fixed in place, spaced out over the floor but again nailing through two pre-drilled nail holes into each rail. The gaps of about **8-10mm** between boards serve as drainage holes but, if desired, additional filler boards could be cut and fitted.

12 Cut and fix cross bars:

From the five pieces of 50 x 25 x 600mm DAR cut **five cross bars** each 600mm long. Fit each cross bar at the marked lines, evenly spacing the bars across the trellis posts. Fix the top bar in position first, using one 50 x 8gge screw at each post ensuring that the trellis posts will be parallel. Fix remaining cross bars.

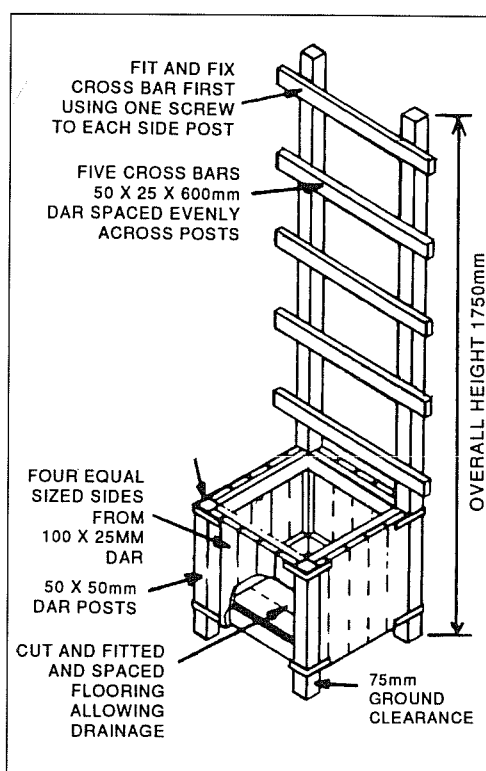

13 Finish planter box

by sanding off all sharp corners and edges to desired standard. Apply the selected paints, stains or coatings, as recommended by the manufacturer. Note that exterior grade finishes should be used if the planter box is to be exposed to the weather.

Alternative Sizes: Using this design of four posts and attached corner brackets, it is possible to adjust the size of the planter box to suit the width of alternative side planks and fabricated side panels.

Similarly, the height of the box can be adjusted by lengthening the front posts and height of side panels. However, we suggest that overall height of trellis be kept to 1750mm which would enable the box to be transferred upright through a normal sized door.

Disclaimer: While the Timber and Building Materials Association (NSW) Limited (**TABMA**) and its members believe this publication is an invaluable guide to this project, the Association cannot guarantee that every statement is without flaw. Therefore, the Association and its members hereby disclaim all liability for errors or omissions of any kind, whether they be negligent or otherwise, or for any loss, damage or other consequence which may arise from any person relying on information stated in this publication.