

# Ranch Fences

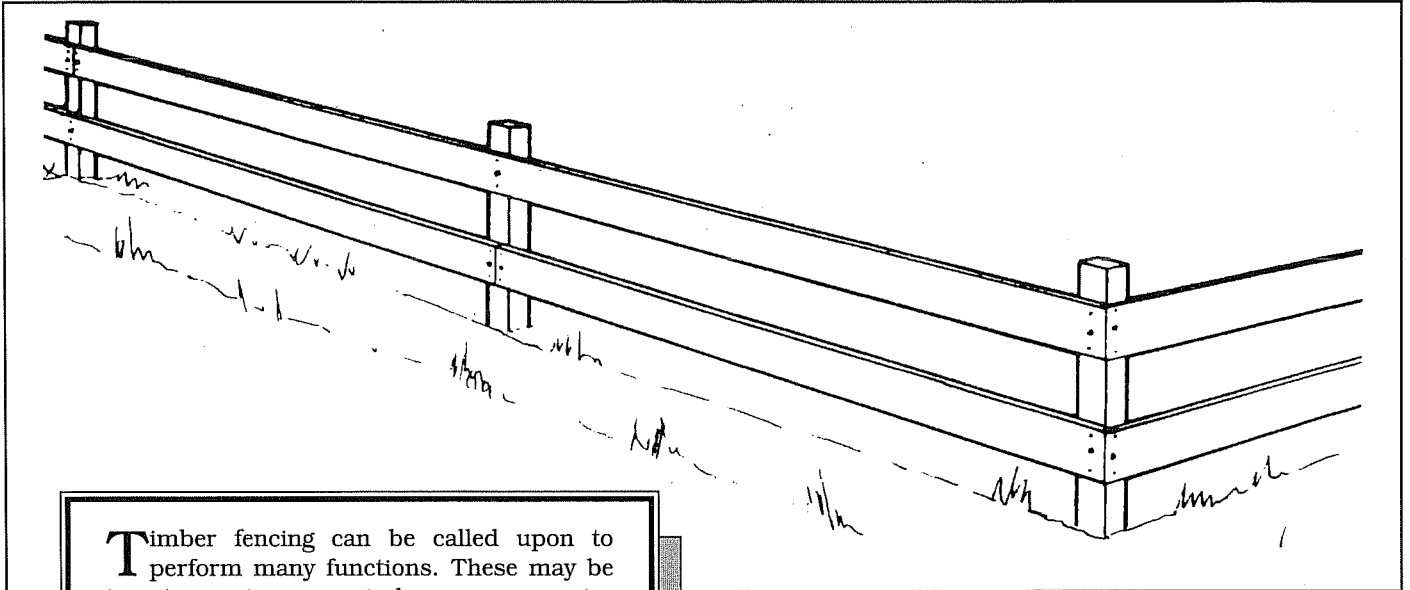

**T**imber fencing can be called upon to perform many functions. These may be to act as privacy or wind screens, as noise barriers or as simple boundary markers. At this present time, in major metropolitan areas, a fencing contractor is usually employed to erect the standard paling fence which runs along side boundaries. Many timber merchants have knowledge of contractors who will perform this task efficiently and at low cost. Special decorative safety fences are described in T.D.A. publication 'Timber Safety Fences and Gates for Pools' which gives designs for domestic poolside timber fences which would comply with the appropriate regulations. However, this handyman project is concerned with a simple decorative ranch-type timber post and rail fence which uses only simple butt joints, and is suitable for a street front fence or, if the neighbours are friendly, could be used as an attractive side-boundary fence.

## TOOLS YOU WILL NEED

- Saw
- Hammer
- Measuring tape and pencil
- Carpenter's square
- String line and level
- Spirit level, plumb bob is useful
- Drill and bits
- Spanner
- Post hole digger (preferred) or other tools for digging post holes

## MATERIALS YOU WILL NEED

(Note: for this example only)

### TIMBER

(Durable timber should be used. Consult your timber stockist on availability)

**Posts:** 100 x 100mm x 1.5m DAR very durable timbers (order sufficient posts for fence according to your plan). The timber merchant will provide timber of standard lengths from which you can cut posts to lengths required.

**Rails:** 150 x 38mm x 4.8m DAR durable timber. Order rail lengths to fit two (or more) panel lengths of fence, number as needed for total lengths of two-rail fence. Your timber merchant will provide timber of standard lengths from which you can cut rails to measured lengths.

### HARDWARE

- 75 x 3.2mm galvanised bullet head nails
- 75 x 9.5mm galvanised coach screws

▼ **STEP BY STEP** ▼

**1 TIMBER SELECTION:** Because fences are exposed to the elements and posts in particular are in ground contact, the choice of timbers must be restricted to those which are durable under those severe conditions. For in-ground posts very durable timbers are preferred which usually restricts choice to selected hardwoods, cypress pine, CCA treated pines or particular grades of western red cedar or redwood. For other fence components exterior above-ground durability is desirable but a wider range of timbers is suitable. Consult your timber stockist on what is available and suitable for this project. The timber can be dressed-all-round (DAR) to a smooth surface or in rough sawn condition. Both seasoned and unseasoned timber may be used.

**2 DESIGN OF FENCE:** A simple fence consists of posts embedded firmly in the ground and the rails. Two or more rails can be used depending on the appearance required. Posts are normally spaced evenly along the fence line. A typical ranch-type post and rail fence is sketched and construction described.

**3 PLANNING FENCE:** Measure the length of fence required and calculate the number of posts needed. It is advisable to draw out on paper a sketch of the fence layout. Posts should be about 2.4 metres apart giving panels of equal length where practical. Rails should run over two panel lengths of the fence, again where practical, but should be 'staggered' on posts so that joins of the upper and lower rails do not occur on the same post. With the aid of this planning diagram you will be able to calculate or count the number of posts required and the number of lengths of railing needed.

**4 PRELIMINARY WORK:** If possible in the early stages of preparation there is benefit to be gained by treating the base or bottom portion of all posts with creosote or similar water repellent fungicidal mixture. It is preferable to actually soak that below-ground portion of post in the treating fluid. However, if this is not practical, then three heavy brush coats of creosote applied on that portion of post which will be below ground, particularly all end grain sections and about 100mm of the post above ground is one compromise alternative. Allow the brush coats to dry before proceeding with setting out fence.

**5 SETTING OUT POSTS - Where to start:** Corner and finishing posts should be erected first. The centre of the post should be positioned over the line of the fence. Dig post holes 750mm deep, provide tamped but free draining material at bottom of hole.

The tops of these posts should be set at the required height of the fence above the ground.

For our example, this height is 0.8 metres above ground line. Firmly brace the corner and finishing posts as shown in the sketch so that they are vertical and exactly located on centre line of fence. Tamp in soil around braced posts up to about 300mm from ground line.

With both end posts braced in position run a string line from corner to corner attached to the face (front) side of the posts (See sketch).

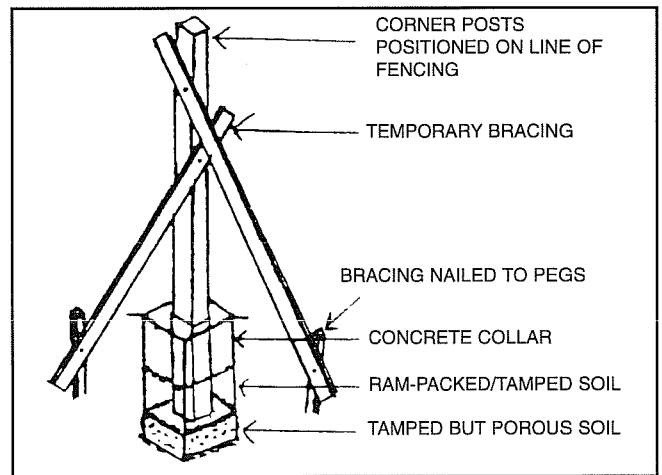

**6** Using a steel measuring tape, the length of the fence may now be divided into panels (the distance between two adjacent posts). The panel widths should not exceed 2.4 metres and wherever possible should be adjusted to increments of 300mm (the basic length module used by the timber industry). Thus rails would be cut from standard lengths with minimum wastage. However, timber should be ordered in lengths which enable rails to cover two panelling lengths.

**Example: A fence is 50 metres long 50m - 2.4m = 20.8 panels approx.**

To assist ordering and for better appearance we would suggest 21 panels at 2.38 metres between centres of posts so that rail timber would be ordered in minimum 4.8m lengths.

**7** The remaining post hole centres can now be marked with small pegs driven in the ground (i.e. 2.38m apart in our example) using the straight edge and spirit level method or plumb-bob method shown in the sketch, to locate centres of posts.

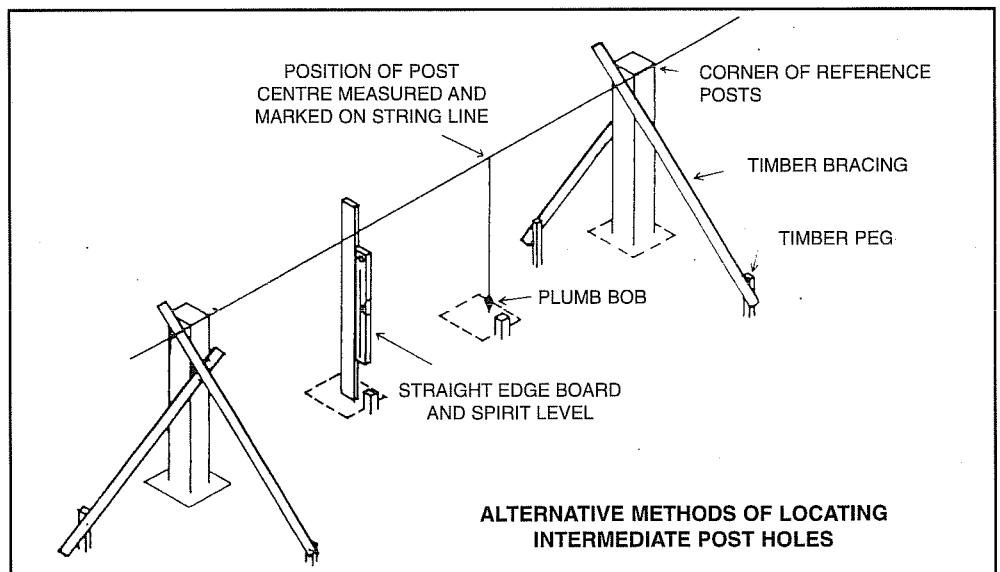

- 8 EXCAVATE POST HOLES:** Excavate post holes to 750mm depth, accurately centered on pegged point.
- Note:** You should devise some method of allowing water to drain away from bottom of posts in free draining sandy soil. This is not a problem, but in clayey soil you could set the post on a tamped layer of free draining material like gravel, pebbles, ashes etc.

- 9** Mark position of rails on posts as indicated in this sketch. Width of rails may vary as can gap between the rails and the bottom rail and ground line.

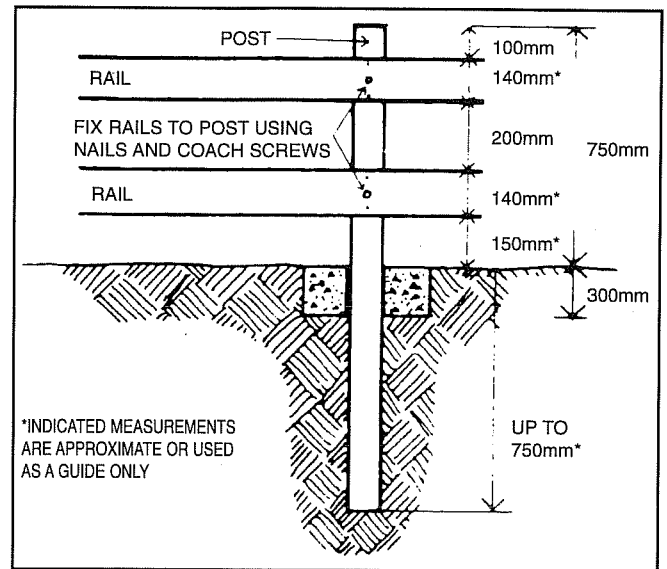

- 10** Locate the posts in holes but do not yet attempt to fill in. Instead, remove soil or fill hole to give each post the desired height above ground as set by the string line. For a ranch (post and rail) fence, the string line contour can also indicate where oversize posts could be cut as an alternative method to give the desired fence line. Firmly tap soil around post to about 450mm depth, ensuring that post is vertical and located correctly using string line and spirit level.
- 11** Cut rails to required lengths as indicated in sketch. That is the first and last rails in both upper and lower line have allowance for end posts thickness but thereafter all rails are double or more panel lengths and butt-joined at mid-point of posts.

LINE UP OF POSTS AND RAILS SHOWING USUAL ARRANGEMENT OF BUTT-JOINING RAILS

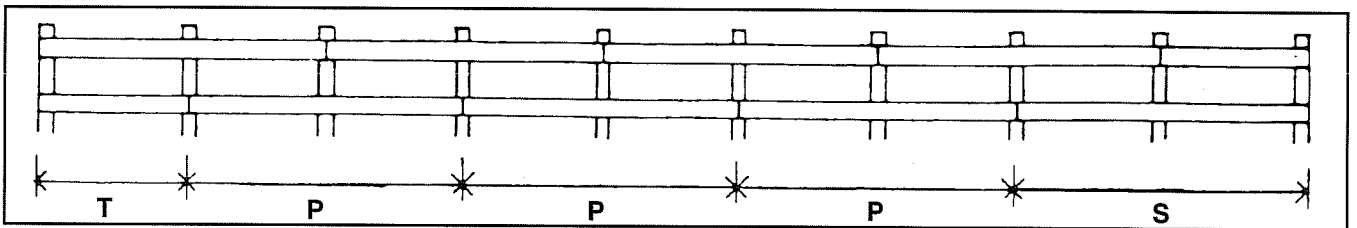

In our example (see Step 6) dimension 'P' should be standard double post spacing of 4-76m (4760mm), dimension 'S' would be approximately  $4760 + 45\text{mm}^* = 4805\text{mm}$ , dimension 'T' is approximately  $2380 + 45\text{mm}^* = 2425\text{mm}$ . Note that with adequate planning, rails of three panel length could be used, but avoid putting butt-joints in upper and lower rail on the same post if possible (\*45mm is half the width of 100 x 100mm DAR posts).

- 12 LOCATE** rails in position on the posts by fastening them with one nail per post until all rails are in place. Follow the jointing pattern shown in Step 11 which avoids joining both bottom and top rails on the same post. Butt joints should be located on centre lines of posts.
- 13 CHECK ALIGNMENT** of post by string line and run of rails by eye and adjust if necessary, then complete nailing fence using two nails at each post. Where butt joints occur, pre-drilling nail holes in ends of rails is recommended.
- 14** As an added strengthener, reinforce nailing with one coach-screw at each junction of post and rail.
- 15** Complete consolidation of posts in holes using a concrete collar at each corner or end post and firmly tamped rubble or soil, or a shallow concrete collar, around all other posts up to ground line.
- 16** Using plane, Surform tool or electric sander, remove all accessible sharp corners from all the posts and rails (i.e. chamfer or arris all corners to improve paint/stain adhesion).
- 17** Stain or paint fence using exterior grade finishes as required. It is recommended that all end grain of rails and posts be thoroughly primed or sealed with stain or paint.

## ALTERNATIVE FENCE FOR SLOPING SITES

Using the same general principles, fences to fit sloping sites could be as below.

**Note:** posts are always vertical and on the line of fence. Ideally each three posts should be linked by at least one continuous rail.

### STYLE A

For slight regular slope, using posts of fixed length.

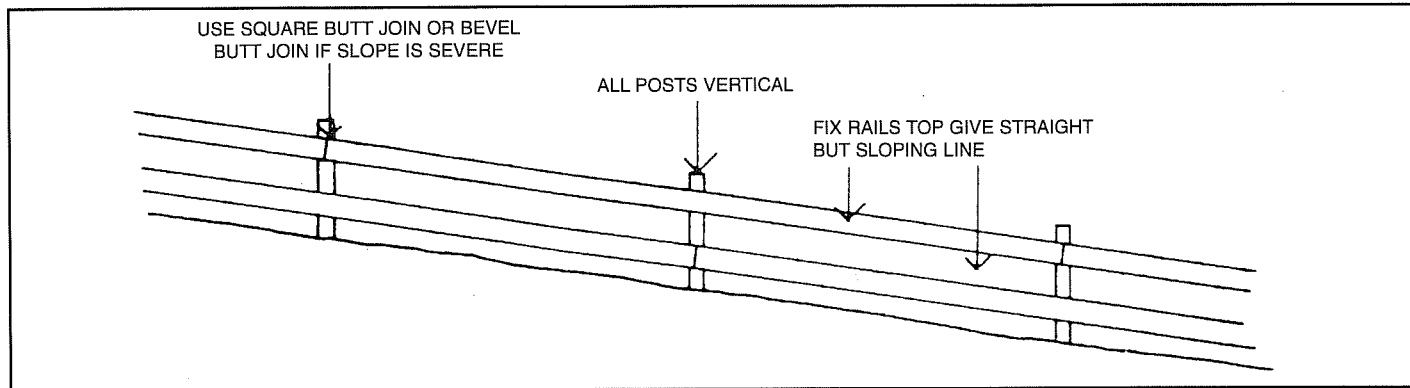

### STYLE B

Stepped post and rail fence for steeper slopes - note variation in post height.

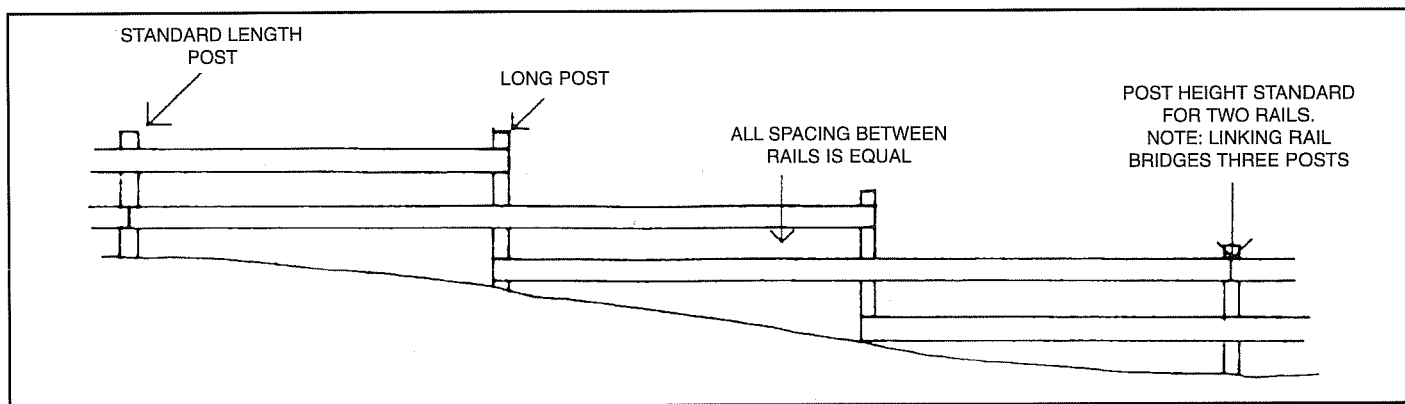

### STYLE C

Double/triple rail and post fence.  
Provides additional privacy, could use thinner section rails.

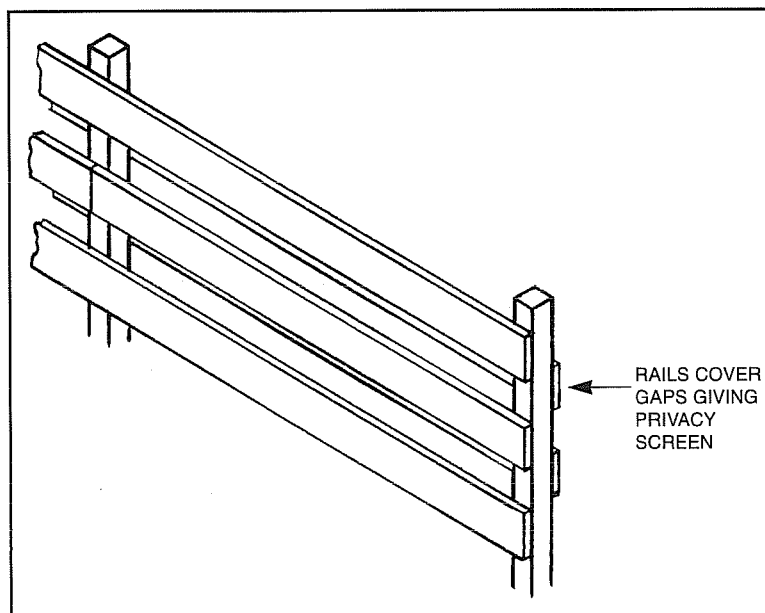

Supplied by