

Timber Ranch Gate

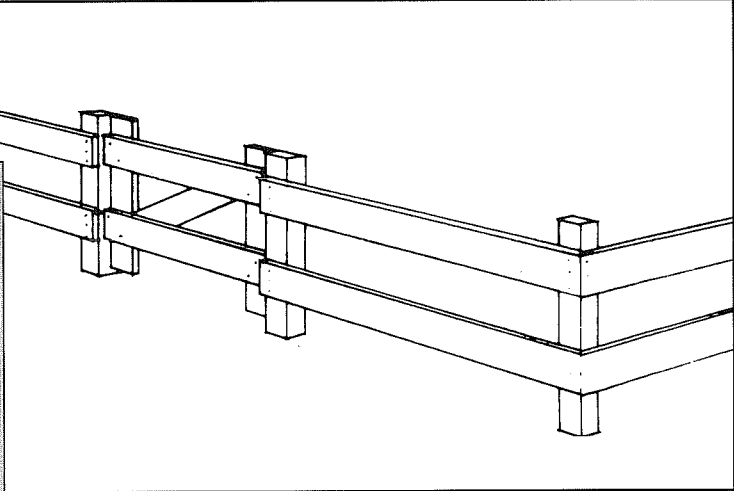

Timber and Building Materials Association (NSW) Limited

Construction of a low level post and rail fence is described in HANDYMAN PROJECT NO. 8. Here in this project we give a design for a gate to match that post and rail fence. Gates give control of access through fences but frequently are merely part of a boundary marker, as in this design, rather than an security screen. Safety gates in fences around domestic swimming pools are also a special case and should be constructed for both safety and as required to satisfy local government regulations. Swimming pools require Safety Gates and Fences which satisfy local government regulations.



STEP BY STEP

TOOLS YOU WILL NEED

- Saw • Hammer • Measuring tape/rule • Carpenter's square and pencil • Drill and bits • Spanner • Chisel
- Spirit level, string line, plumb-bob is useful • Post hole digger (for gate post holes)

MATERIALS YOU WILL NEED

(Note: For this example only)

TIMBER

Durable timber should be used for the gate. **Very durable** timber should be used for posts which are to be in ground (Consult your timber stockists about what timbers are available and suitable for this project.)

Posts (for this example only) - 100 x 100mm x 1.5m DAR - 2 required.

Rails, Brace and Stiles (for this example only) - 150 x 38mm DAR: 1 piece 1.5m for 2 stiles, 1 piece 2.1m for 2 rails; 1 piece 0.9m for diagonal brace.

Stop Mould (for this example only) - 38 x 38mm DAR, 1 piece 0.9m.

HARDWARE

- 10 - 75 x 8mm galvanized cup head bolts, nuts and washers.
- 2 - 100mm Scotch T, heavy duty, galvanized hinges.
- 30mm x 8gge, countersunk head, wood screws, galvanized, to fit 'T' hinges.
- 65 - 2.8mm bullet head nails (for temporary fixing).

1 TIMBER SELECTION: Because gates are exposed to the elements and posts in particular are frequently in ground contact, the choice of timbers must be restricted to those which are durable under those severe conditions. For in-ground posts very durable timbers (*see note) are preferred which usually restricts choice to selected hardwoods, cypress pine, CCA preservative treated pines, western red cedar or redwood. For other gate components exterior above-ground durability is desirable but a wider range of timbers is suitable. (Consult your timber stockist on what is available and suitable for this project.)

For gates and posts the timber can be dressed-all-round (DAR) to a smooth surface or in rough sawn condition. Both seasoned and unseasoned timber may be used. If unseasoned timber is used on the gate then tightening and squaring the gate could be required after 6 months. Where possible, lower density (light weight) timber is preferable for gates so as to reduce the load on hinges and braces.

***Note:** Preservative treatment of the in-ground portion of some timber posts may be useful. Apply several full flood brush coats of readily available creosote (or equivalent proprietary water repellent/fungicide) to the in-ground portion of the post and to 100mm above ground/concrete line.

2 GATE COMPONENTS: No matter what design of gate is used, it is essential that the gate posts are firmly fixed to existing walls or embedded firmly in the ground. Gates also require some form of diagonal bracing, which effectively supports the weight of the gate. Hardware (hinges, latches, pad bolts etc.) should be corrosion resistant (e.g. galvanized) for longer life.

3 LOCATE GATE POST HOLES: Dig hole for post(s) in location decided in relation to fence or wall. Provide hole(s) 750mm deep with free draining base of sand, gravel or similar.

4A POSITION POSTS in prepared holes, locating them using string line or fence rails to give straight line with fence as required and at height decided in relation to fence. Brace post(s) vertically as necessary using timber braces. (See diagram in Project 8.) Fill in hole with rammed earth at base then fill remainder of hole with earth/cement mixture or a concrete collar to ground level.

4B POST ON WALL: Where gates will be located abutting an existing brick or masonry wall, thinner section timber posts could be used. In this case, as shown in diagram, locate posts on existing wall and mark proposed position of fastening bolts on post, then drill necessary holes for bolts. Using bolts as indicators and with post hand-held in position on wall, locate position of bolts in brickwork, then proceed to drill appropriate sized holes, insert expanding plug type masonry bolts, etc., and fix fence post in position. (See diagram.)

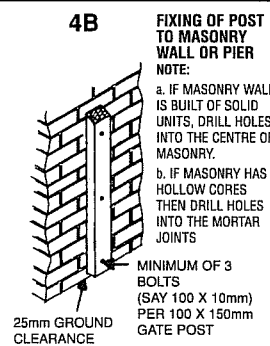
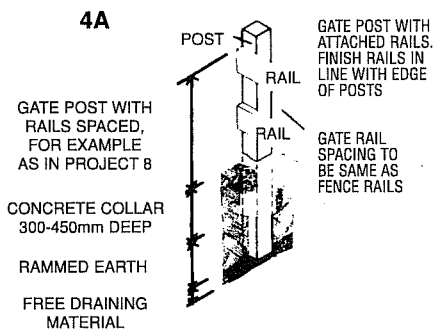

5 CHECK MEASURE DISTANCE BETWEEN POSTS before concrete has set and confirm desired gate opening, and that gate posts are vertical and aligned with each other.

6 CUT RAILS: from the piece 150 x 38mm x 2.4m DAR cut two rails each 25mm less than the actual measured gate opening.
Example: If distance between posts is 1m (or 1.000m) cut two rails 975mm long.

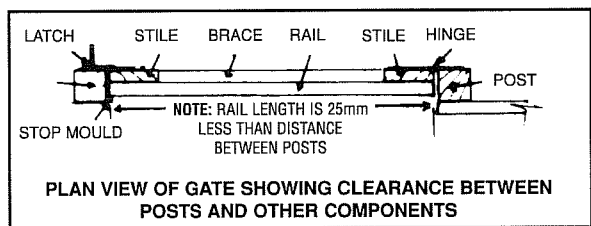

7 CUT STILES: From the piece 150 x 30mm x 1.5m cut two stiles each the height of the posts above the ground, less 25mm.
Example: For fence posts 750mm height above the ground cut two stiles, each 725mm long to allow 25mm ground clearance.

8 LAY OUT FRAME using rails and stiles at spacing necessary. Line up rails to match the spacing on the ranch fence as in Project 8. Lightly nail rails in position on the stiles using two 65 x 2.8mm galvanized nails at each junction, but leave nail heads protruding for later withdrawal, if necessary. It is essential that the framework be temporarily fixed square.

9 CUT DIAGONAL BRACE: Take the piece 150 x 38 x 900mm and locate it on the gate framework and mark it out to fit as shown. Then cut the diagonal brace to the shape marked and temporarily nail in place.

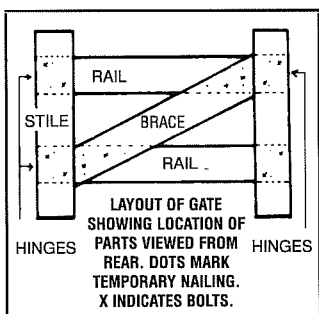

10 CHECK AND ADJUST THE SQUARENESS of the gate assembly then drill holes to accept bolts in junctions of timber (See Step 12). Install bolts, fit and tighten nuts on washers. Heads of bolts would normally be exposed on the front (street) side of the gate. Remove nails if desired.
Note: To achieve a good protective finish on the gate, at this step the gate could be disassembled completely, then each timber component sanded or planed to remove sharp edges and corners and all timber given a prime coat, or a floodcoat of water repellent solution, or the first coat of selected finish as recommended by the paint manufacturer. When the first protective coating is dry, the gate would be re-assembled using only the bolts and nuts as fasteners.

11 LOCATE GATE IN FENCE OPENING, allowing equal spacing each side and bringing rails horizontal and in line with existing fence rails. Put small blocks or similar between bottom of stiles and ground to hold gate in this position. Gate stiles should be in line with rear of gate posts and parallel to them.

Supplied by

12 LOCATE TOP HINGE on posts and stiles, mark position of screws so that they clear all nuts and bolts. Repeat this procedure with bottom hinge and drill pilot holes, etc., then fix top hinge.
Note: At Step 10, you could temporarily locate flap of hinges in position on stiles so that bolt holes could be drilled to clear hinge flaps. It is preferable to locate hinges lined up roughly on centre line of rails and over diagonal brace to give full hinge attachment.

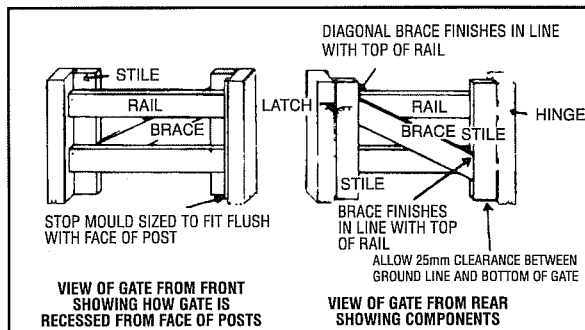

13 FIT PAD BOLT OR LATCH (as selected) to stile or rail as required.

14 NAIL FIX STOP MOULD to post on closure side. In this example (see diagrams in Step 12), a stop mould can be fitted over the whole length of the closure post, after planning or trimming back to finish flush with face of post, as necessary. In this case, the rails of the gate strike the stop mould at the latched position. None of the closing impact should be taken by the latch.
Alternatively, a short stop mould of square section 38 x 38mm DAR timber could be nailed to posts so that gate strikes the stop mould positioned between the rails.

15 APPLY FINISHES (see note in Step 10). Sand or plane off all edges of stiles, rails and diagonal braces, etc., including all accessible end grain, preparatory to applying the recommended coats of selected exterior grade finishing system. Always apply the selected finishes as instructed by manufacturer.

DOUBLE GATES: Using the same principles of construction as given here, you can construct a set of double gates, provided some of the measurements are changed to fit the larger opening. If the same timber sections are used then a fence opening up to 2.4m can be covered by two equal sized (1.2m each) gates. Usually the 150 x 38mm DAR timber nominated for this low level fence/gate structure would be adequate for gates up to 1.2m length. This sketch shows position of braces and gate block appropriate for low, equal sized double gate. Note also that these double gates could be fabricated in one piece, cutting apart to give two gates when all bolts, etc., are tightened. Allow for 10mm clearance between hinge side of gates and posts and 10-20mm between gates at centre. The stop mould normally on gate posts is replaced by an adequately sized or firmly positioned gate block for centre of gate and the latch components or pad bolts are fitted to the central stiles.

